

Table of Contents

Agenda	2
Authorization to Advertise 2015 Delinquent Real Property AuthorizationToAdvertise2015	3
January 11, 2016 Regular Town Council Meeting Minutes January 11, 2016 Regular Town Council Meeting	4
Public Hearing: Review and Consideration of Public Hearing for the preliminary plat application for the Conservation Subdivision, The Enclave at Weddington Staff Report - Enclave.	23
Review and Consideration of Entry Monument Application for the major subdivision, Weddington Preserve Staff Report - Weddington Preserve	26
Entry Monument Application	27
Update from the Town Planner Update from Town Planner	30
Code Enforcement Report Code Enforcement Report	31
Finance Officer's Reports Stmnt of revenues & expend Feb 2016.	33
Balance sheet Feb 2016	36
Update from Tax Collector January2016TaxReport.	37
Feb2016UnpaidList.	39
Public Safety Report Public Safety Report	49

**TOWN OF WEDDINGTON
REGULAR TOWN COUNCIL MEETING
MONDAY, FEBRUARY 8, 2016 – 7:00 P.M.
WEDDINGTON TOWN HALL
1924 WEDDINGTON ROAD
WEDDINGTON, NC 28104
AGENDA**

Prayer – Mayor Bill Deter

1. Open the Meeting
2. Pledge of Allegiance
3. Determination of Quorum
4. Special Recognition of John Giattino for his service on the Planning Board
5. Presentation and Consideration of the FY 2014-2015 Audit by Tinsley and Terry

PUBLIC ADDRESS TO THE COUNCIL

Any individual or group who wishes to address the Council may do so at this time. Each speaker will have three (3) minutes to make their remarks and shall obey reasonable standards of courtesy in their remarks. Typically, this is a time for the Mayor and Council to hear from the public and not respond. If questions are raised, a member of the Town Council or Staff may contact the individual after the meeting to help address issues raised. If the item you wish to speak about is a Public Hearing item, address your concerns during that time and not under the Public Comment period.

6. Public Comments
7. Additions, Deletions and/or Adoption of the Agenda

CONSENT AGENDA

The Council may designate a part of the agenda as the "Consent Agenda." Items placed on the consent agenda are judged to be non-controversial and routine. Any member of the Council may remove an item from the consent agenda and place it on the regular agenda while the agenda is being discussed and revised prior to its adoption at the beginning of the meeting. All items on the consent agenda shall be voted on and adopted by a single motion, with the minutes reflecting the motion and vote on each item.

8. Consent Agenda
 - A. [Review and Consideration of 2015 Authorization to Advertise Unpaid Taxes](#)
 - B. Call for public hearing: Review and Consideration of Text Amendment to Section 58-543 of the Zoning Ordinance to fix an incorrect reference to a separate section of the Zoning Ordinance

9. Approval of Minutes
 - A. [January 11, 2016 Regular Town Council Meeting](#)

The Public must sign up before the beginning of the meeting to speak on an item under Public Hearings. The Mayor will recognize speakers in the order in which their names appear on the sign-up sheet. The Council sets the rules for the Public Hearing. The rules may include, but are not limited to, rules fixing the maximum time allotted to each speaker; providing for the designation of spokespersons for groups of persons supporting or opposing the same positions; providing for the selection of delegates from groups of persons supporting or opposing the same positions when the number of persons wishing to attend the hearing exceeds the capacity of the Town Hall; and for providing for the maintenance of order and decorum in the conduct of the hearing.

Each speaker must address the Council from the lectern and begin their remarks by giving their name and address. Each speaker will have three (3) minutes to make remarks. A speaker may not yield any of his or her time to another speaker. Speakers must be courteous in their language and presentation. Personal attacks on the Council or members of the public will not be tolerated.

The Mayor may determine whether a speaker has gone beyond reasonable standards of courtesy in his or her remarks and shall rule on objections from other members of the Council on discourteous behavior. A majority vote of the Council may overrule the Mayor's ruling on standards of courtesy. Speakers may leave written comments and/or supporting documents, if any, with the Town Clerk to the Council.

10. Public Hearing and Consideration of Public Hearing
 - A. [Review and Consideration of Public Hearing for the preliminary plat application for the Conservation Subdivision, The Enclave at Weddington](#)
11. Old Business
 - A. Septic Tank Update
 - B. Update and Consideration of audio recordings of Town Council meetings
 - C. Consideration of Security Alarm System Upgrade
12. New Business
 - A. [Review and Consideration of Entry Monument application for Weddington Preserve](#)
13. [Update from Planner](#)
14. [Code Enforcement Report](#)
15. [Update from Finance Officer and Tax Collector](#)
16. [Public Safety Report](#)
17. [Transportation Report](#)
18. [Council Comments](#)

19. Adjournment

TO: Mayor and Town Council
FROM: Kim H. Woods, Tax Collector
DATE: February 8, 2016
SUBJECT: 2015 Authorization to Advertise

In accordance with North Carolina General Statute 105.369(a), the following represents the total of unpaid 2015 taxes that are liens on real property to date:

\$ 40,384.26

In accordance with General Statutes 105.369(a), I am hereby requesting authorization to advertise unpaid 2015 taxes that are liens on real property.

State of North Carolina
Town of Weddington
To the Tax Collector of the Town of Weddington

The Town of Weddington Tax Collector is ordered to advertise all unpaid 2015 taxes that are liens on real property, pursuant to North Carolina General Statute 105-369(a), -369(c).

Witness my hand and official seal this 8th day of February, 2016.

Bill Deter, Mayor

Attest:

Peggy Piontek, Town Clerk

**TOWN OF WEDDINGTON
REGULAR TOWN COUNCIL MEETING
MONDAY, JANUARY 11, 2015 - 7:00 P.M.
MINUTES**

The Town Council of the Town of Weddington, North Carolina, met in a Regular Session at the Weddington Town Hall, 1924 Weddington Road, Weddington, NC 28104 on January 11, 2016, with Mayor Bill Deter presiding.

Present: Mayor Bill Deter, Councilmembers Michael Smith, Scott Buzzard and Janice Propst, Town Attorney Anthony Fox, Finance Officer Leslie Gaylord, Town Planner Julian Burton, and Town Administrator Peggy Piontek

Absent: Mayor Pro Tem Don Titherington

Visitors: Bill Price, Ginny Reid, Bill Snider, Monica Snider, Andy Stallings, Peggy Stallings, Dan Barry, Larry Wood, Marcos Bilbao, Walton Hogan, Barbara Harrison, Pat Harrison, Anna-Marie Smith, John Roberts, Brent Michael, Pam Hadley

Mayor Bill Deter offered the Invocation prior to the opening of the meeting.

Item No. 1. Open the Meeting Mayor Deter opened the January 11, 2016 Regular Town Council Meeting at 7:00 p.m. He announced that Mayor Pro Tem Titherington is not present this evening.

Item No. 2. Pledge of Allegiance Mayor Deter led in the Pledge of Allegiance.

Item No. 3. Determination of Quorum There was a quorum.

PUBLIC ADDRESS TO THE COUNCIL

Any individual or group who wishes to address the Council may do so at this time. Each speaker will have three (3) minutes to make their remarks and shall obey reasonable standards of courtesy in their remarks. Typically, this is a time for the Mayor and Council to hear from the public and not respond. If questions are raised, a member of the Town Council or Staff may contact the individual after the meeting to help address issues raised. If the item you wish to speak about is a Public Hearing item, address your concerns during that time and not under the Public Comment period.

Item No. 4. Public Comments

Mayor Deter opened Public Comments.

Barbara Harrison, 2001 Belle Forest Court - My comments are directed towards Councilwoman Propst. In your Council comments you said –“ because if you knew me you’d know this town is very important to me”. In fact this town is so important to you that you voted to sue the town for \$750,000.00. This town is so important to you the town has incurred additional attorney fees that you and you alone are responsible for. The taxpayers of Weddington would like for you to recuse yourself when it comes to deciding and voting on anything dealing with the Providence Volunteer Fire Department. The fact is on May 11th and August 10th you pounded this podium and let everyone know what was important to you (Providence Volunteer Fire Department). Another of your comments was “I will do it with honesty, integrity and openness”. In that vein we would like to know if Providence is awarded the \$750,000.00 how much do you anticipate receiving? Gentlemen thank you for your service.

Walt Hogan, 5009 Laurel Grove Lane – First off I want to wish everyone a Happy New Year. Second I’d like to reopen the issue of the \$206,000.00 that has just kind of disappeared from discussion. Third thing I’d like to recommend that we in Weddington recommend against the 50 year toll up on 77. Thank you.

Bill Snider, 1423 Longleaf Court – As far as the intersection at Antioch Church Road and Long Leaf Court is concerned, I don’t know how many people here have to go through that intersection every day. I know you have probably heard a lot from residents. It is pretty dangerous. When I say dangerous, not to talk about myself but a little bit of background and I’ll try not to use up three minutes. I have worked within NASCAR for a lot of years and I’ve been around fast cars, accidents, safety issues, developing seats, seatbelts, and all kinds of stuff. That intersection has a blind hill coming from your left. I can’t tell you how many times I’ve seen it happen and it’s happened to me, where if you’re turning left out of that intersection and somebody is coming up the left side over 45 miles per hour. My theory on this is if you put a 35 mph speed limit people go 45 if you put 45 and they go 55. I pulled out of there one day, I had a guy in a BMW M3, and luckily I was turning right. He went into the opposite lane of traffic and almost went off the road trying to avoid me and he had to be doing clearly 60 mph. This is somewhat routine. The reason I bring this up is because you have the Falls at Weddington being built. All these extra houses and now you’re talking about the Enclave and you will add traffic from that as well. Although I’ll probably be the one to get caught going 2 miles over the speed limit there really isn’t a lot of police presence over there looking at what people are doing. That’s what I wanted to say about the intersection. I do think it’s really, really dangerous. Thank you for your time.

John Roberts, 1415 Longleaf Court – Thank you for the opportunity. I live next door to Mr. Snider. I’m also here to speak about Antioch Church Road and specifically Longleaf Court

which is the Providence Place neighborhood. I've lived in the same location for almost 20 years. Just before I moved to Providence Place (several of my neighbors remember this) -Antioch Church Road, right where we are, was a gravel road. It was paved just about 20 years ago on the portions that we are concerned about. There is a crest hill on Antioch Church Road right at the intersection of Longleaf Court that has been there all this time. The issue that we are concerned about now is the significantly increased traffic that is on Antioch Church Road now and will be increasing over the next year. I'm told about 450 homes are currently under construction or under development within a mile of this intersection I'm talking about. Some of you know that I have been quite involved in business and commerce in Union County from the time I've been here. I've been through all the stuff that this Council, not you personally, but your predecessors in particular with the growth in Union County, Providence Road, Rea Road, and Highway 84. Those of us over where we live in Weddington haven't asked for much over the last 20 years because there hasn't been much activity going on over there. The land wouldn't perk but now we have sewer and the land is really going to be developed by the landowners. We're increasing and I predict that Antioch Church Road will be the next Rea Road in Union County. We need to address that now. Some of you are working with us with DOT. I know that you have limited authority within DOT so I know you can't make any decisions but you can certainly come down on the side of supporting us from the safety issue of this intersection. We would very much appreciate you doing that when you have the opportunity. Thank you very much.

Mayor Deter closed Public Comments.

Item No. 5. Additions, Deletions and/or Adoption of the Agenda

Councilman Michael Smith moved to accept the agenda as presented by staff. All were in favor, with votes recorded as follows:

AYES: Councilmembers Buzzard, Propst, Smith

NAYS: None

Consent Agenda. *The Council may designate a part of the agenda as the "Consent Agenda." Items placed on the consent agenda are judged to be non-controversial and routine. Any member of the Council may remove an item from the consent agenda and place it on the regular agenda while the agenda is being discussed and revised prior to its adoption at the beginning of the meeting. All items on the consent agenda shall be voted on and adopted by a single motion, with the minutes reflecting the motion and vote on each item.*

Item No. 6. Consent Agenda

A. Approval of the 2016 Meeting Schedule

Councilman Smith moved to accept the Consent Agenda and to approve the 2016 Meeting Schedule. All were in favor with the votes recorded as follows:

AYES: Councilmembers Buzzard, Propst, Smith

NAYS: None

Item No. 7. Approval of Minutes

A. December 14, 2015 Regular Town Council Meeting

Mayor Deter confirmed that the Council had seen the final revision the Town Clerk sent out this afternoon.

Councilman Scott Buzzard moved to accept the December 14th Regular Town Council meeting minutes as presented by staff. All were in favor with the votes recorded as follows:

AYES: Councilmembers Buzzard, Propst, Smith

NAYS: None

The Public must sign up before the beginning of the meeting to speak on an item under Public Hearings. The Mayor will recognize speakers in the order in which their names appear on the sign-up sheet. The Council sets the rules for the Public Hearing. The rules may include, but are not limited to, rules fixing the maximum time allotted to each speaker; providing for the designation of spokespersons for groups of persons supporting or opposing the same positions; providing for the selection of delegates from groups of persons supporting or opposing the same positions when the number of persons wishing to attend the hearing exceeds the capacity of the Town Hall; and for providing for the maintenance of order and decorum in the conduct of the hearing.

Each speaker must address the Council from the lectern and begin their remarks by giving their name and address. Each speaker will have three (3) minutes to make remarks. A speaker may not yield any of his or her time to another speaker. Speakers must be courteous in their language and presentation. Personal attacks on the Council or members of the public will not be tolerated.

The Mayor may determine whether a speaker has gone beyond reasonable standards of courtesy in his or her remarks and shall rule on objections from other members of the Council on discourteous behavior. A majority vote of the Council may overrule the Mayor's ruling on standards of courtesy. Speakers may leave written comments and/or supporting documents, if any, with the Town Clerk to the Council.

Item No 8. Public Hearing and Consideration of Public Hearing

A. Review and Consideration of Public Hearing for the preliminary plat application for the Conservation Subdivision, The Enclave at Weddington

Mayor Deter opened the Public Hearing.

Bill Snider – 1423 Longleaf Court – Along the same lines of what I said before, the concern I have about this new development is the construction traffic that is going up and down Antioch Church Road. I don't know if those roads were designed for the logging trucks that are going up and down there. It seems to be holding up better than I thought. But the truth of the matter is every day I drive on the road it seems like every day there's a new pot hole. I know you probably aren't responsible for that. But now when you add Enclave into it and if they have got to use Antioch Church Road it can't help but cause more damage to it. It's typically on the edges of the road where pot holes are developing. In some way, shape or form I wish it was going down Hemby. Sorry if any of you live on Hemby but it is tearing the road up a lot. That was my comments. Thank you

Town Planner Julian Burton – This is a 42 lot Conservation subdivision located off of Antioch Church Road, access on Antioch Church Road. The applicant is still working through construction document review with our engineering consultant. Staff and the applicant both felt it would be best if the Council would consider tabling the Public Hearing and the vote until next month at least - until they are able to get the second round of review comments from Bonnie Fisher addressed.

Town Attorney Anthony Fox – If you do decide to table it with the Public Hearing not having been closed, additional people will have the opportunity at the next Council meeting to continue to comment publically about the proposed plan.

Mayor Deter – Okay, so we just leave the Public Hearing open. Do we need a motion to move it to next month?

Town Attorney Fox – I think the motion is to recess the Public Hearing with regards to Enclave and to table. Maybe the easiest thing to do is to just table the Public Hearing with the understanding that the Public Hearing will remain open. That's the better motion. To table consideration of this item which is Review and Consideration of Public Hearing for the preliminary plat application for the Conservation Subdivision, The Enclave at Weddington until the February meeting of the Town of Weddington with the Public Hearing remaining open until that time.

Councilman Smith moved to table the hearing for the Enclave of Weddington until the February meeting leaving the Public Hearing open. All were in favor with the votes recorded as follows:

AYES: Councilmembers Buzzard, Propst, Smith

NAYS: None

Item No. 9 Old Business

A. Septic System Update

Town Administrator Peggy Piontek - We discussed this at the December meeting. I have been in contact with Chief McLendon and he informs me that he has spoken with the contractor about the septic project. He will call him next week when they plan to come to the fire station and start their process. I will keep you informed as we move forward. Once they determine what we need to do whether it's get a larger tank or extend the line.

Mayor Deter – At that point that's when we go out for bids.

Town Administrator Piontek – Yes, if there's anything else that needs to be done staff will bring it back to you.

B. Update and Consideration of audio recordings of Town Council meetings

Town Administrator Piontek - We discussed this at the December meeting. I have been in contact with our IT vendor and our Website vendor. I have ordered and received a digital recorder. We are recording tonight's meeting for testing purposes only. Total cost for this has been less than \$300.00. The digital recorder was \$249 and the website vendor was \$25. You can go onto our website, click on Documents & Forms and you will now see an addition to that drop down box titled Audio. Once we have data to put on there, the year then the meeting date will be listed.

Councilman Smith – Are you going to be the one that puts it on the website?

Town Administrator Piontek – Yes, either me or our IT vendor. If you want to go forward with this, let me know. There currently is no way to edit this.

Councilman Smith – Is there any additional cost for them to have this put on our website?

Town Administrator Piontek – No, that's all part of the deal.

Mayor Deter – A couple of questions have come up. During a discussion if a Councilperson states that he will be away, then afterwards they realized they just informed all the crooks to rob me. In paper minutes that would not be included but on a recording it will be. What is our ability on something like that? Is it just up to Council and other people to pay more attention to what we say?

Town Attorney Fox – For purposes of the law it only requires that your Town Clerk has a duty responsibility for recording the minutes of all public meetings of the town. The recordation requirement is not an audio requirement. It is to just reflect as accurately as possible what has transpired during the course of the meeting. It's not required to be verbatim. To the extent of

you doing an audio on the website because you're not required to do the audio it will be within the Town's discretion to determine how much of the audio recordings they wish to put on public forum like that.

Mayor Deter – Is there any public records restriction on how long we have to maintain it?

Town Attorney Fox – There will be that, once you create it then you have the Department of Archives Requirement.

Town Administrator Piontek – I checked into that and I forwarded you those emails. The Department of Archives, as well as the School of Government, has informed us that once you have approved the written minutes those are your official documents. They have no requirement for you to maintain these audio recordings because technology advances so quickly that if you have a cassette deck or play a video they would be obsolete. Their approach is that five years from now you may not have the equipment to play the audio that you are recording now. That will not be your official record. Your official document will be your printed minutes.

Town Attorney Fox – That's correct because technology is getting so advanced and we have these capabilities now. But the law as it currently provides doesn't require you to keep verbatim minutes of what transpires at a meeting. What happens though is you have some inconsistencies with the public records provisions that state anything that is produced in carrying out a public business, regardless of the form, is a public record. It puts on you that obligation to maintain that. What you would do if you were to move toward audio is to establish some type of policy that would say we are providing on our website an audio of the most recent minutes. These audios are not verbatim; that liberties have been taken when possible to safeguard certain information. For instance Social Security information, addresses some of that stuff may be sensitive to what you want to post. You need to think about what kind of policy you want to do if you go forward with this.

Councilman Buzzard – If we set it up as letting them know on the website that they are just drafts, my understanding is that once you have something official past a draft then the draft becomes obsolete. Is that correct?

Town Attorney Fox – Again it depends on how broadly you read the requirements from public records. In some situations drafts can also be construed a public record. I haven't talked to the Institute to see if they have had this question come up with regards to audio records.

Mayor Deter – I don't want to rush this along, between now and the February meeting we can get discussions and clarity on policy.

Town Administrator Piontek – I will be happy to forward you the emails from the School of Government and the Archives. I thought I had but if not, I'll be happy to forward to you again. So we are not going to go forward.

Councilwoman Janice Propst – I think we are going to discuss it further but my comment was that if we are going to do audio, unless someone says a negative or a really bad word I'm against

someone having the ability to edit. I might be the one who hates what I said in the comments but once I said it in the meeting I want it to be recorded.

Mayor Deter – I think that’s some of the stuff we have to discuss.

Councilwoman Propst – I agree if he’s on vacation.

Mayor Deter – That’s the discussion on how we address these issues.

Councilwoman Propst – I think it’s worth discussing further.

C. Update on Community Development Block Grant Program

Mayor Deter – Union County has a program through the Federal Government on Block Grant Programs. In order for them to get that they were trying to get support from the other municipalities within the County. It’s basically for low to moderate income, leaning towards low income. In Weddington you are not going to have a lot of that but we thought it would be beneficial for the County to help them get the grants so we voted in favor of it. Peggy meets with them monthly or whenever they meet to represent the town. We did have a meeting with them just this past week. They were very thankful that we voted to do this and are trying to find something here in Weddington. One of the things we discussed was Birch Haven Road. Julian, are you familiar with that? You go down Weddington Matthews Road there’s a gravel road there. Turn left on Birch Haven there’s about five mobile homes down there. I checked on the GIS maps and it looks like its part of a big parcel so I don’t know whether that’s something that will qualify.

Town Planner Julian – I don’t know if it qualifies or not. I didn’t look it up again after we spoke. It does look like it was originally designed to be a mobile home park so it’s not separate parcels or lots. It’s several mobile homes on one big parcel.

Mayor Deter – I guess the update to Council is if you are aware of something in the town, mainly geared towards infrastructure, water, sewer, road, low income that’s something we could submit for a grant request. So if you come up with some ideas or maybe someone in the audience has some ideas get them to me or Peggy.

Town Planner Burton – I’ll bring it up to the Planning Board as well.

Councilwoman Propst – I have one question, wasn’t that only \$20,000.00 to \$30,000.00 that was there? Isn’t that minimal?

Town Administrator Piontek – Yes, it was minimal but I think the guidelines require lower to medium income areas. It’s my understanding there are some areas in Weddington that might qualify. That’s why they were thinking of certain areas.

Mayor Deter - \$20,000.00 to \$30,000.00 a year for five years. There’s a small portion of the bulk sum that we might get these funds for from the Federal Government.

10. New Business

A. Discussion and Consideration of Critical Intersection Analysis

Town Planner Burton – Union County has received funds to perform a study of some intersections that are problematic either from a safety perspective or a traffic perspective in the County. They want to join up with all the municipalities in Union County to come up with a list. What the idea would be ultimately is to do some preliminary study and project design for the intersections that are selected. They are thinking about 15 in the County. That way when there is an opportunity to be considered for a State or Federal project/funding we have the framework in place to submit that quickly and make the process a little more efficient as the traffic is continuing to get worse and growth is obviously increasing at a high rate in the County. They want a list from all the municipalities by Friday. It's a short turn around so I apologize for that but as you know I asked all of Council and the Planning Board as well for some feedback on intersections they felt would qualify to be further looked at and are causing problems. One conversation I had was with Joe Lesch who is the Senior Transportation Planner, and who has been organizing this. We do have two major projects slated in 2019 and 2021 which is the Rea Road Extension and Providence Road. Although he said you don't necessarily have to rule out projects along those two roads, he would recommend trying to identify some intersections that are outside of those projects since those are going to get taken care of potentially with those bigger projects anyway. That being said I know that Council has some concerns, the Planning Board as well, of a few areas especially along Providence Road that are in pretty bad shape now and maybe it's not worth waiting until 2021. I think it would be important to certainly include some outside of those projects in our list. He asked for three. If it's four or five, that's certainly okay as well. It's not a hard line but I think the first step will be submitting them and I will be serving on the Advisory Committee as well. There is a project team and I think they will do some preliminary level of service, traffic and accident data study of the ones that are put forth by municipalities and go from there and try to whittle it down to 15 in the County. They will try and space them out as well so it's all not going to be in Monroe. They are trying to geographically space out those intersections throughout the County. There's a good chance Weddington can at least get something included in that list.

Mayor Deter – He is looking for something \$1,000,000.00 to \$2,000,000.00 or less. Smaller projects and they are looking for a municipality contribution of 15% was the number he threw out. So \$1,000,000.00 we would be looking for the Town to support about \$150,000.00. Julian put out a list you have and you can see on the back side. The Rea Road extension for all intents and purposes under DOT planning is a done deal. The Providence Road is 2021 or beyond.

Town Planner Burton – I still believe that both of those projects are a done deal.

Mayor Deter – That's going to happen? Okay. I guess I will open it up for discussion with Council.

Town Planner Burton – I will make one quick addition. I separated out the list into two different sections. One for intersections outside those two major projects and another for intersections that were included inside the projects or were slightly outside the Town of Weddington. I did leave out one that had two mentions, Providence and Ennis Road. That would be in the second list if you want to add that one in.

Councilwoman Propst – So we all pretty much mentioned the first five at the top in some way or another.

Town Planner Burton – Planning Board is included in that as well. There were five that were outside of those major projects that were included.

Mayor Deter – For example the first one Weddington Matthews Road and Tilley Morris. I'm assuming three people mentioned those specifically. You said included in the LARTP.

Town Planner Burton – That was an intersection that had already been identified in the Regional Transportation Plan as something that would need improvement.

Mayor Deter – That's not the section of Tilly Morris we were working on with DOT?

Town Planner Burton – No, that's the Yield sign where Weddington Matthews approaches. The first five are intersections outside of the major projects of Providence Road and Highway 84/Rea Road. The first one is Weddington Matthews Road and Tilley Morris which had three mentions and is included in the LARTP. The second is Cox Road and Highway 84. This is actually not within the Rea Road/84 portion because it picks up further east. On that three mentions. Beulah Church Road and Twelve Mile Creek Road had two mentions. Also included in the LARTP. Antioch Church Road and Longleaf Court had two mentions and was also discussed earlier tonight. Forest Lawn and Potter Road had one mention but that is also included in the LARTP. Those that are included within the major project areas or are outside of Weddington are Twelve Mile Creek Road and Highway 84 which had five mentions and is also in the LARTP. I kind of grouped together Cottonfield Circle and Lochaven Road with Providence Road because they are so close together and that had four mentions. Just as a side note, Lochaven Road is also going to undergo some improvements as part of the Weddington Preserve subdivision. There will be a left turn lane going into Lochaven Road. I know there was some concern should there be a right turn out from there as well. Providence Road and Ennis Road had two mentions. That's further south on Providence Road. Twelve Mile Creek and New Town Road had one mention. There is really only one corner of that intersection that is in Weddington. That doesn't mean we should rule it out. Antioch Church Road and Highway 84 is part of the major project and it's not in Weddington.

Councilwoman Propst – I'm fine with the five we have because the rest of the ones at the bottom are going to be addressed. So the top five that we have are already kind of agreed upon.

Councilman Buzzard – It might be too that the five that are not necessarily in Weddington or partly in Weddington might be picked by another municipality.

Councilman Smith – It definitely would behoove us to stick with the five if we are really trying to accomplish something here.

Town Planner Burton – I can also just suggest those five and then maybe include the ones on Providence Road as well. Just as a suggestion if they are looking at Providence Road at all for them to take a look at these two intersections.

Mayor Deter – What I'm hearing from Council is to go with the top five. Weddington Matthews Road and Tilley Morris that's basically where the yield sign is. Cox Road and Highway 84, does that involve turn lanes? If they come and ask us what we mean by Cox Road and Highway 84?

Town Planner Burton – I don't think we necessarily need to say what it would be. It's just that it would be an improvement of some kind.

Councilwoman Propst – There's no signal light there.

Mayor Deter – Beulah Church Road where Twelve Mile Creek Road comes into that. That's deadly. I live around there. Antioch Church Road and Longleaf Court we have a couple of people that spoke to that tonight.

Town Planner Burton – I did ask Joe today to confirm that it would fall within the criteria because it's not truly an intersection. He was fine with it being there.

Mayor Deter – Forest Lawn and Potter Road. So we can go with those five, Council is in agreement. Or we can go with those five and then do a 5 A & B.

Councilwoman Propst – Twelve Mile Creek and 84 is going to be handled with Rea Road so that's already addressed. Like you said with the improvements with Lochaven already with that Weddington Preserve.

Councilman Smith – The only problem I would have other than the ones at the top there, if it's going to be absorbed by other projects are we mudding the water?

Councilwoman Propst – That's what I'm saying, the top five are the top five.

Councilman Smith – Yes, I would like to leave it at that.

Councilman Buzzard – We have Julian who is going to be part of the process. I think the fact that he knows what we've discussed he has an idea if other discussions should come up.

Mayor Deter – The only place I was trying to go with this is there were four mentions, which is one of the highest, is it simple to put a stop light at Cottonfield? Because anyone coming out of Cottonfield cannot make a left hand turn. It's difficult to come out and make a right hand turn then turn around. Once we get the left hand turn lane into Lochaven, you definitely won't be able to get out of Cottonfield. If you have a stop light signal there at Cottonfield, that's stopping traffic which will also create a little gap for people coming out of Lochaven to be able to make that right turn. So a signal seems like a pretty simple thing to do but it addresses several issues. That's why I'm suggesting we make that a 5A.

Town Planner Burton – I agree that it’s a huge problem, but the only push back is when they expand Providence that’s not where they would put a light. Because they are putting lights at other locations.

Mayor Deter – I agree, I’m not sure what he means by short term. We’re talking five years to get Providence started. Five years is a long time. We will grow and have more traffic. I was just throwing it out, it’s up to Council.

Councilman Smith – I think they will probably take a look at it. It’s pricey to put a stop light in. I’m thinking they may not do it because of that. But I see what you’re saying and I agree with it. I would be worried if we piled too much on that top list that some of the other things that we need to get done won’t get done because they will focus on that.

Councilman Buzzard - The other thing too is that nothing says that just because we have this list we are precluded from working on projects ourselves.

Councilwoman Propst – How much is a stop light?

Councilman Smith – It’s over \$1,000,000.00.

Councilman Propst – Never mind.

Councilman Buzzard moved that we send the first five projects that are not included in the major project areas or outside of Weddington as per the recommendation. All were in favor with the votes recorded as follows:

AYES: Councilmembers Buzzard, Propst, Smith

NAYS: None

Intersections outside Highway 16 and Highway 84/Rea Road projects:

1. Weddington-Matthews and Tilley Morris (3 Mentions) – *Included in LARTP*
2. Cox Road and Highway 84 (3 Mentions)
3. Beulah Church Road and 12 Mile Creek (2 Mentions) – *Included in LARTP*
4. Antioch Church Road and Longleaf Court (2 Mentions)
5. Forest Lawn and Potter Road (1 mention) – *Included in LARTP*

B. Discussion and Consideration of Easter Egg Hunt and Litter Sweep

Mayor Deter – The person that used to do that is no longer on Council. I would like to keep this going. It is some initial funding from Council. This is in the budget and I am looking for support from Council that we should continue these events.

Councilman Smith - Who’s going to do it?

Mayor Deter - Right now me and some staff members. I've had a meeting with Barbara, several discussions with Peggy and Tonya. We've set a date for the Easter Egg Hunt on March 19th and Litter Sweep on April 15th. We have a sequence of things that need to be done. Yes, I will do it.

Councilman Smith – I'm in favor of I; I'll give you a hand.

Mayor Deter – Okay. We have it down here for discussion and consideration, but I think we just need consensus from the Council. It's good for the Town and hundreds of people attend.

Councilwoman Propst – I was going to say that two Council Members should work with the staff to work on these two events. That's why I wanted to bring it up to begin with. I felt like those are two good events that the Town should continue with. We have a lot of companies that support it as well.

By consensus the Council agreed to continue to have the events.

C. Discussion and Consideration of Proposal from Centralina Council of Governments for facilitating the retreat in February

Mayor Deter – Our last several town retreats we brought in an outside facilitator from COG. It helps keep us on track. They actually do pre-survey interviews with Council to help identify the issues. We do have it budgeted. The bid they gave us is actually below the budget. So we are looking at, on this particular one, we have a contract in here.

Town Administrator Piontek – The original contract that went out with your packet was renegotiated by Mayor Deter. You received a revised contract over the weekend and I have placed a hard copy on your desk this evening.

Finance Officer Leslie Gaylord – How much is it, Peggy?

Town Administrator Piontek - \$2,000.00

Finance Officer Gaylord – Okay I was going to comment that it was significantly higher than that before.

Town Administrator Piontek – If Council moves to approve the contract, you will be approving the revised contract of \$2,000.00, not the one in your packet.

Councilman Buzzard – What was the contract last year?

Finance Officer Gaylord - \$1,500.00 but we were advised it would go up. We were aware there was going to be an increase.

Town Attorney Fox – I've looked at the contract in the package and it is acceptable.

Councilman Smith moved to accept the Centralina Council of Governments contract for facilitating the retreat for \$2,000.00. All were in favor with the votes recorded as follows:

AYES: Councilmembers Buzzard, Propst, Smith

NAYS: None

D. Discussion and Consideration of Proposal from Firethorne Country Club for the retreat in February

Mayor Deter – This is where we hold the retreat.

Councilman Smith moved to accept both the Thursday and Friday proposal from Firethorne Country Club for the retreat. All were in favor with the votes recorded as follows:

AYES: Councilmembers Buzzard, Propst, Smith

NAYS: None

Item No. 11. Update from Town Planner

Town Planner Burton – Pretty similar to last month's update. Again Mayor Deter and Councilman Buzzard, the orientation for CRTPO will be on Wednesday night. Another DOT project, the Rea Road extension as we discussed tonight, the Public Hearing is January 26th at Graceway Baptist Church. There is a portion that is just open to the local officials will be between 2:00-4:30 pm. Then there is an open house for the public followed by a formal presentation. It will go until 8:30 p.m. Subdivision information is similar to last month which is included in the memo in the packet.

Item No. 12. Update from Finance Officer and Tax Collector

Finance Officer Gaylord – You have the monthly statements in your packet. Councilwoman Propst was kind enough to inform me that the attorney fee line item, the general representation amount accidentally got recorded as litigation. So that for the month the general representation amount should be \$7,322.00. That would reduce the litigation by that same amount.

Mayor Deter – Is that line item 192?

Finance Officer Gaylord – Yes, line item 192 and 193. There is no change in the total; it's just a split between the two. I will make an entry to fix it.

Mayor Deter – Okay, so of the \$16,000.00 for the current period, \$7,322.00 will move into general?

Finance Officer Gaylord – Correct. The auditors will be here at the February meeting to present the financial statements. Tax Collector Kim Woods has done a bang up job collecting taxes. If you think they look good on here you should see the ones for January; they are even better. So we are doing good.

Item No. 13 Public Safety Report

Councilman Smith – There was a Public Safety Committee meeting on January 5th of this year, it was their first. They nominated their Chairman and Vice-Chairman. They put a nice plan together to try and put some definition and direction to the Committee. They are coming up trying to formulate a handbook so as committee member's terms expire this can be passed on. It will show what direction they were heading in and get some continuity. It's a pretty good idea. All of this is being worked on now. I did discuss with them some of the things we wanted to go over at the retreat. I did discuss many of these items with them about nine months ago. I told them that, more than likely, there would be some more definition to it once the retreat was completed. Some of the things I had mentioned were pot holes. Forming a committee to go out and identify pot holes to deal with DOT. Then identifying some road issues. They are aware that this is coming down and that the Council is going to be wanting them to do that. They also are looking into the CERT Trailer and if it has any meaning to it. Those are just some of the things they are working on. More than likely, within the next several months we will get a report back from them as to where that stands. If you have anything that you want them to work on, either go through me or contact them directly.

Item No. 14. Transportation Report

A. Discussion and Consideration of voting on I 77 Toll Road

Councilman Buzzard - I am looking for some direction from Council. Obviously it is a big item in our area and North Charlotte. I have not been to any of the MUMPO meetings so I don't know the culture or climate within the organization. I'm green on this one and am looking for some thoughts and direction.

Councilwoman Propst – I spoke before the meeting when you read the things on line, it looks like a lot of the communities north of the city are opposed to the tolls. I guess it's really going to depend on what Charlotte says. Marvin voted against it. Is that Correct?

Mayor Deter – The first time yes.

Councilwoman Propst – Have they voted again?

Mayor Deter – Well, they haven't voted again but it's already been approved once.

Councilwoman Propst – I know, once. I just read the things on-line. Personally I was against car toll roads to begin within the Charlotte area. But then you begin to read that there will no

longer be HOV lanes. They will go away. The fees, the tolls will leave the Country and I think Town Attorney Fox can explain why that is a little bit better?

Town Attorney Fox – The way toll works out the concession contract works state the contractor is paying in advance for the construction of the roads. Carrying all the costs for the construction of the road. He's building into those costs traffic or revenue studies to look at how much traffic would generate certain amount of revenues over a period of time. They also have to build into it certain maintenance reserves to maintain the road. It is designed to allow the contractor to recover over a period of time in term of years; it's investment in the property with a certain percentage of return. So that's what it's tied to.

Mayor Deter – Basically you have to know your revenue, they have to construct it, maintain it, and pay their bond holders, the cost of money over time. Then what's left after that is profit. As far as leaving the Country?

Town Attorney Fox – Some of the larger concession players in this industry are foreign. The Chicago Loop, some of the construction occurred there was funded by that. Greenville, that went bankrupt outside of 85 South, was rescued by a Spanish company.

Councilwoman Propst – Should we ask our previous MUMPO Representative since she's here tonight if she would like to speak on this for the people in the community?

Mayor Deter – I don't know if we can procedurally do that. I can tell you we directed Ms. Harrison the first time to vote for it for various reasons. Near as I can tell none of those reasons have changed since we voted for it the first time. You are correct Janice, the towns up north tend to be against it, but that's after they were for it in the beginning. Now they are against it. Most of the areas down here are in favor of it. With the exception of Marvin and I'm not sure why.

Councilwoman Propst – I think Mineral Springs is on record. Like I said I was trying to get more information before I decided on anything tonight.

Mayor Deter – I went to the meeting; it was well attended. Every municipality in Union County was there. There were presentations, there were questions and answers. Realizing that it was presented by NCDOT so they are going to put a slant on it. Personally, I think the toll lane is a good thing.

Councilman Smith – Let me ask you this, my understanding is you can opt out. You don't have to pay; it's just for one particular lane right?

Mayor Deter – There will be two lanes each way, I can't remember how far. Then there will be an additional lane going up to Iredell County. Then basically the toll lanes are required to maintain a 45 mph speed limit, so when the other lanes are doing 5 mph, the toll lanes hum along at 45 mph. The way they do that is by car count. Approximately 1,700 cars is what they can handle and maintain 45 mph. They will have sensors and it is dynamic pricing. When they start

approaching that 1,700 car limit, which means traffic is going to slow down, contractually they will have to keep it at 45 mph. That's when the price goes up which will depress the demand, reducing the number of cars in that lane.

Councilman Smith – My question is you don't have to be in that lane to go on the Highway?

Mayor Deter – You will be sitting in the existing lane as it is now. If you are an HOV person, which currently takes two people to be in the HOV lane, under this toll lane it becomes three people. You can still do the HOV thing but three people. There will be transit busses that will be in that express lane that moves along. There are options. I've already said that I think this is a good thing, so take what I'm saying from my point of view. They could build two more lanes and you know how this area is growing, in five years from now they will be full. I think everyone has seen the 10 lane Interstate in China on the internet. In my opinion if you don't create toll lanes that's where you are going to go. It's going to force a bit of social engineering. There has to be an incentive to get people to change their driving habits. One of those incentives is you can car pool with 3 people, you can take alternate transportation. There are a number of options, but that's what it's going to take to get people to change their driving habits.

Councilwoman Propst – Am I right, but it said the contract won't allow for more free lanes for the next 50 years unless there's a stiff penalty? Apparently that's probably still to pay for the toll roads. They won't add additional free lanes because they will still be paying for the toll road.

Mayor Deter – What I was told, again I'm getting this from DOT - you have to take everything where it's coming from - if the State wanted to add lanes on Highway 21, or other roads that tend to parallel that, they can without restrictions. If the toll lanes max out, if the cars they can handle at that 45 mph, regardless of what the fee is the State can come and add another lane on the Interstate because it doesn't impact their revenue. They can't get any more with what they've constructed. But if it's not maxed out and the State wants to come and build another lane, they will reply you are impacting our profit stream here so you have to give us an offset. It's not that the State can't but we will have to pay a penalty but it depends on where the toll lane people are in terms of how fast things go. I was told that the three lanes on 77 South were supposed to be good for 25 years. We're growing and growing and they are rapidly coming to capacity. I think the bigger issue, it's a little late to be getting into this, and it's not so much how much is the toll or I don't want to pay a toll. It's what the long term strategy is for NCDOT in North Carolina going to be. Is it going to be the 10 lane interstate, toll lanes through business government partnerships, toll lanes strictly by the government? So there are a number of different strategies but in my opinion we are pretty far down the road now to be rethinking that strategy or direction. That's from what I've learned.

Councilwoman Propst – Again our vote is very small. If they go forward with the toll lanes there, they also then will move forward with toll lanes on 74 and the empty lane on 485. Is that correct?

Mayor Deter – Not necessarily, that’s separate.

Councilwoman Propst – They might not do those at all though if they don’t get the tolls there.

Councilman Buzzard – My understanding is there are a number of other projects that will be negatively impacted. From what I heard the 77 project is a standalone project as far as moving forward. But if we’re moving backwards...

Councilwoman Propst – Would impact those other projects?

Councilman Buzzard – Correct. Personally I’m not a big fan of toll roads but I agree with Bill that we are far enough down this rabbit hole where I don’t know if we pull the plug even if we vote no it’s going to impact what happens.

Mayor Deter – I think Council needs to give a direction to Scott. I’ve given you spin on it but I don’t vote.

Councilman Smith moved to direct Councilman Buzzard as our Representative to CRTPO to vote in favor of the tolls. The votes were recorded as follows:

AYES: Councilmembers Buzzard, Smith

NAYS: Propst

Item No. 15. Council Comments

Councilwoman Propst – Thanks everyone for coming out tonight. I appreciate your coming and appreciate your involvement in our community. I hope you continue to be involved in the community and come out and be a part of everything we do. Thank you.

Councilman Smith – I second that, thank you for coming out tonight.

Mayor Deter – Thanks for coming out. Hope you continue to come out and come to the Easter Egg Hunt and Litter Sweep.

Councilman Buzzard - I appreciate everyone coming out to the Council meeting. I enjoy seeing more seats filled than not filled. So thank you very much.

Item No. 16. Adjournment

Councilman Smith moved to adjourn. All were in favor, with votes recorded as follows:

AYES: Councilmembers Buzzard, Propst, Smith and

NAYS: None

The meeting ended at 8:07 pm

Mayor Bill Deter

Attest:

Peggy Piontek, Town Clerk

DRAFT

TOWN OF WEDDINGTON

MEMORANDUM

TO: Mayor Deter; Town Council

FROM: Julian Burton, Zoning Administrator/Planner

DATE: February 8th, 2016

SUBJECT: The Enclave at Weddington R-CD Conservation Subdivision
Conditional Zoning Preliminary Plat

Project Information:

The Enclave at Weddington is a proposed 42 lot subdivision on 53.52 acres. The subdivision is located on Antioch Church Rd. and is being developed by Withrow Land Ventures, LLC, as an R-CD conservation subdivision.

A conservation subdivision must base the number of proposed lots on a yield plan per *Section 46-42* of the *Weddington Subdivision Ordinance*. This yield plan must show the number of lots that would be allowed if the tract was developed as a conventional subdivision with 40,000 square foot lots. Conservation subdivisions shall be density neutral (same number of lots as would be permitted in a conventional subdivision). The site density is 0.79 dwelling units per acre. The yield plan was submitted and approved as part of the Sketch Plan application on June 22nd, 2015.

Conservation Land

The conservation land calculations (C-2.0) indicate that 55.1% of the gross land area has been dedicated to conservation land. 50% of the Duke Right-of-Way on the western side of the property was dedicated towards conservation land, as allowed in the *Weddington Zoning Ordinance*.

Utilities

- The Enclave at Weddington is to be served by Union County Public Water and Sewer.
- Fire Hydrants are shown on sheets C-2.1 and C-2.2.

Access and Traffic Analysis

- The subdivision will be accessed by one entrance on Antioch Church Road.
- The Town Planner, in coordination with Justin Carroll, determined that the subdivision did not meet the threshold for a formal Traffic Impact Analysis. The applicant is providing a left

turn lane in to the site and coordinating with NCDOT for design approvals. The Antioch Church Rd improvements are included in Chapter 6 of the preliminary plat submittal.

PIMS

- PIMs were held on June 2nd and June 3rd, 2015, both at Town Hall and on-site.
- Summary of concerns:
 - Buffering and screening between The Enclave and the Preserve at Brookhaven
 - Damage to Antioch Church Road during construction.
 - Length of time for construction

Additional Information:

- Lot 21 is the largest lot at 23,834 square feet or .547 acres.
- Lot 42 is the smallest lot at 12,980 square feet or .298 acres.
- The Cluster Mailbox Unit location is shown on sheet C-2.0.
- The subdivision will include curb and gutter, and sidewalks will be provided on one side of the street and around the culs-de-sacs.

Construction Documents

- The applicant submitted Construction Documents to Town Staff and the Town's engineering consultant, USI, in September of 2015. USI provided their first review comments on October 2nd, 2015, and have just completed the Second Review of the construction documents. The approval letter will be included in your packet, or emailed separately in case it does not make the deadline.

Recommended Conditions:

1. Development subject to review and approval/permitting of construction documents, driveways permit(s), etc. by NCDOT. Applicant must provide proof of approval of the construction documents before commencing with construction.
2. Development subject to review and approval of construction documents by Town's Engineering Consultant, US Infrastructure; Applicant must provide proof of approval of the construction documents before commencing with construction..
3. Development subject to review and approval/permitting of construction documents by Union County Public Works; Applicant must provide proof of approval of the construction documents before commencing with construction.
4. Declaration of Conservation Easement and Restrictions shall be reviewed (by Town Attorney) and executed prior to Final Plat approval by Weddington Town Council;
5. Maintenance Plan and Maintenance Agreement shall be reviewed (by Town Attorney) and executed prior to Final Plat approval by Weddington Town Council;
6. Covenants, Conditions and Restrictions (CCRs) shall be reviewed (by Town Attorney) and executed prior to Final Plat approval by Weddington Town Council;

Planning Board Action (November 23rd, 2015):

Recommended Approval with above-listed conditions - Unanimous

Town Council Action:

Approve/Approve with Conditions/Deny



TOWN OF WEDDINGTON MEMORANDUM

DATE: 2/08/2016
TO: MAYOR DETER; TOWN COUNCIL
FROM: JULIAN BURTON, TOWN PLANNER/ZONING ADMINISTRATOR
RE: WEDDINGTON PRESERVE ENTRANCE MONUMENT REQUEST

Please find the entry monument site plan and architectural plans for the approved major subdivision, Weddington Preserve. The plans show entryway monuments for the entrance off Lochaven Road.

- All monument structures are outside the right-of-way and sight triangles.
- Sign is located on only one side of the entrance. The sign is under the required maximum area of 20 square feet per sign, and the top of the sign is less than 7 feet tall.
- All trees and shrubs are included in the List of Acceptable Plant Species.

Recommended Condition of Approval:

- Any lighting shall meet the requirements of the Town of Weddington Lighting Ordinance.

Planning Board Action:

Recommend Approval with the above-listed condition

Town Council Action:

Approve/Approve with Conditions/Deny

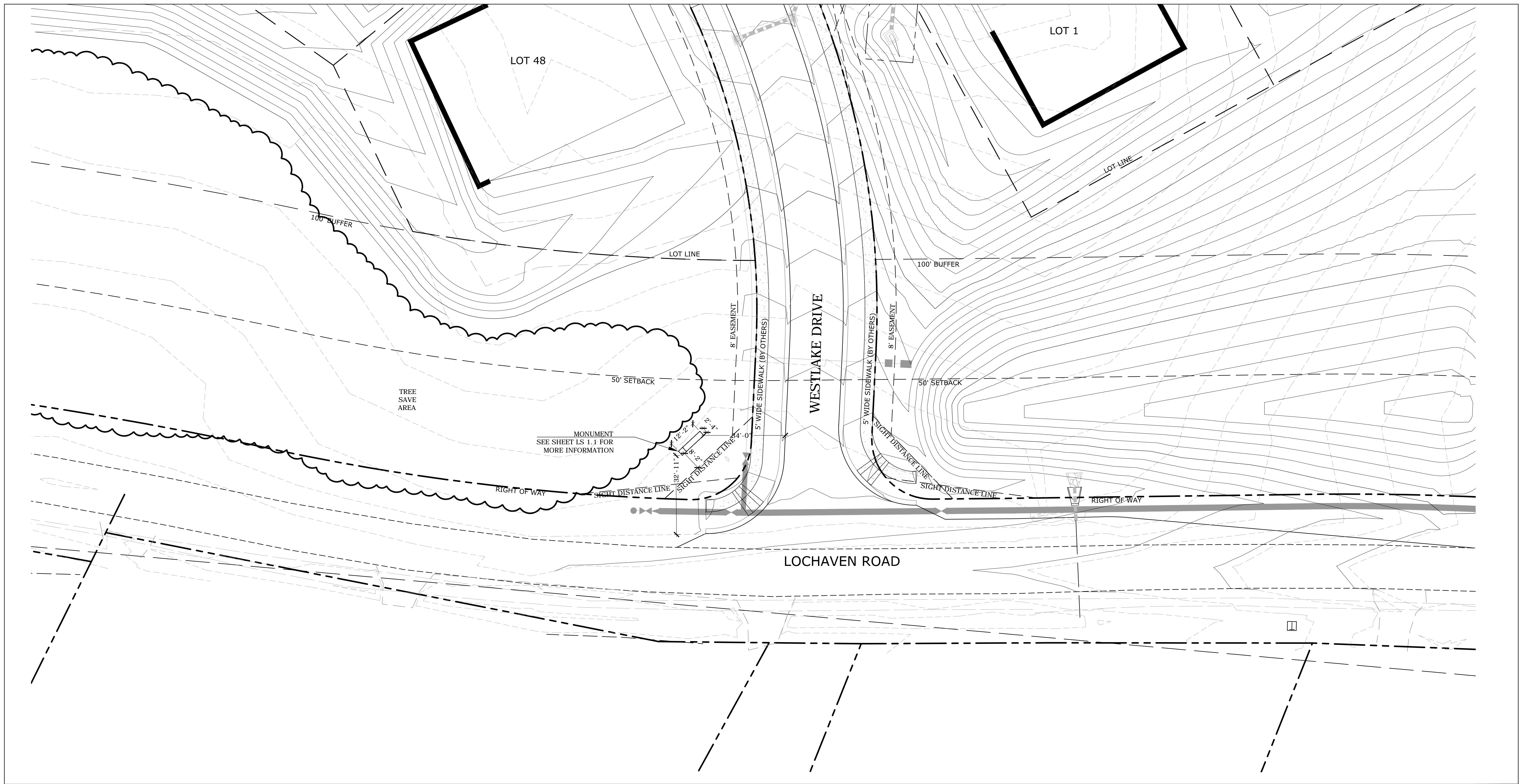

NOTE: CONTACT CARDNO
AT 704.927.9700 FOR A
CAD FILE FOR SURVEYOR
TO UTILIZE IN LOCATING
MONUMENTS IN THE FIELD

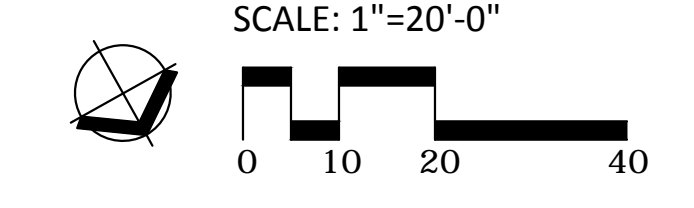

BID SET - NOT FOR CONSTRUCTION

Cardno
Shaping the Future

CHARLOTTE
7606 WHITEHALL EXECUTIVE CENTER DRIVE, SUITE 800
CHARLOTTE, NC 28273
TEL: (704) 927-9700 FAX: (704) 529-3272
www.cardno.com

Pulte Homes
The way it should be

SITE PLAN
WEDDINGTON PRESERVE
PULTE HOMES
Weddington, NC

#	DATE	DESCRIPTION

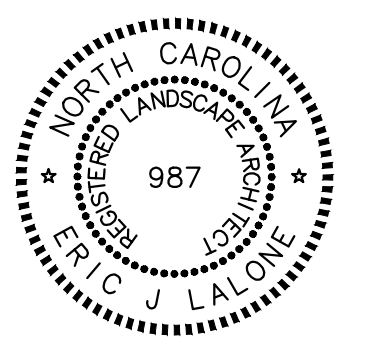

DATE	11-05-15
DRAWN	JPT, JLG
DESIGNED	JPT
CHECKED	EJL, CJC
PROJECT #	1

SHEET TITLE
SITE PLAN

SHEET NUMBER
LS 1.0

LAND USE #

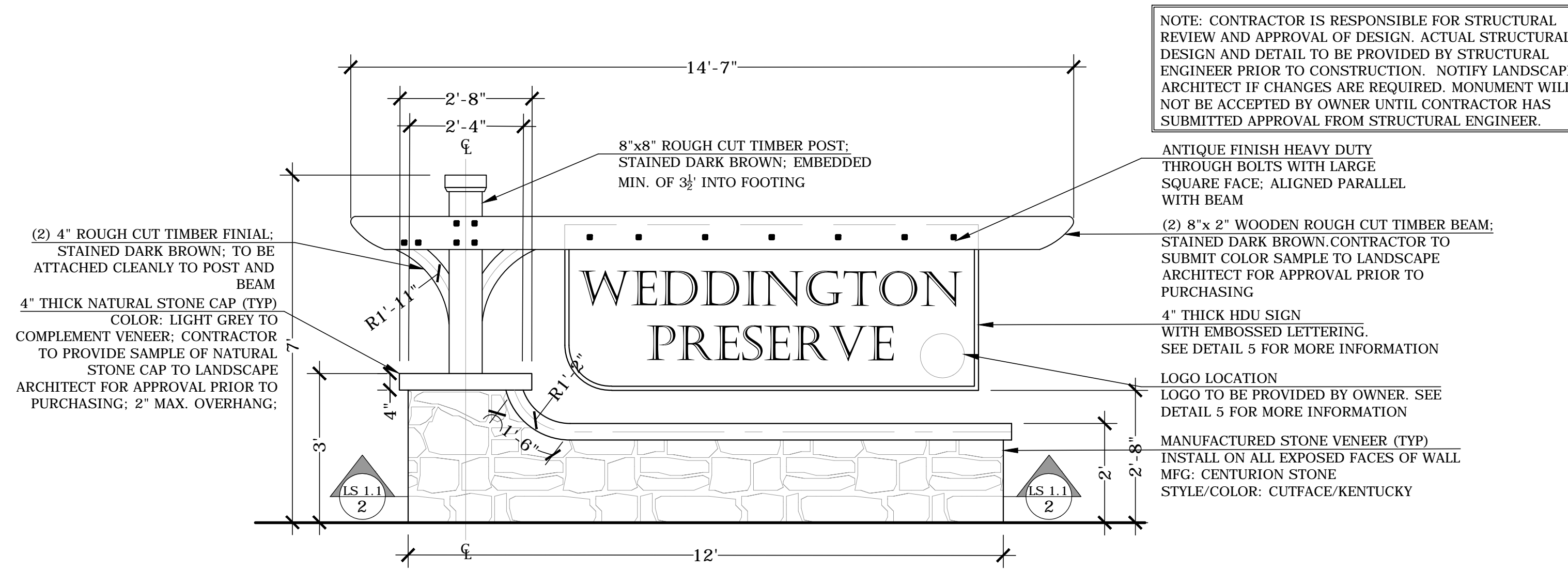

1 MONUMENT ELEVATION - FRONT
SCALE: 1/2" = 1'

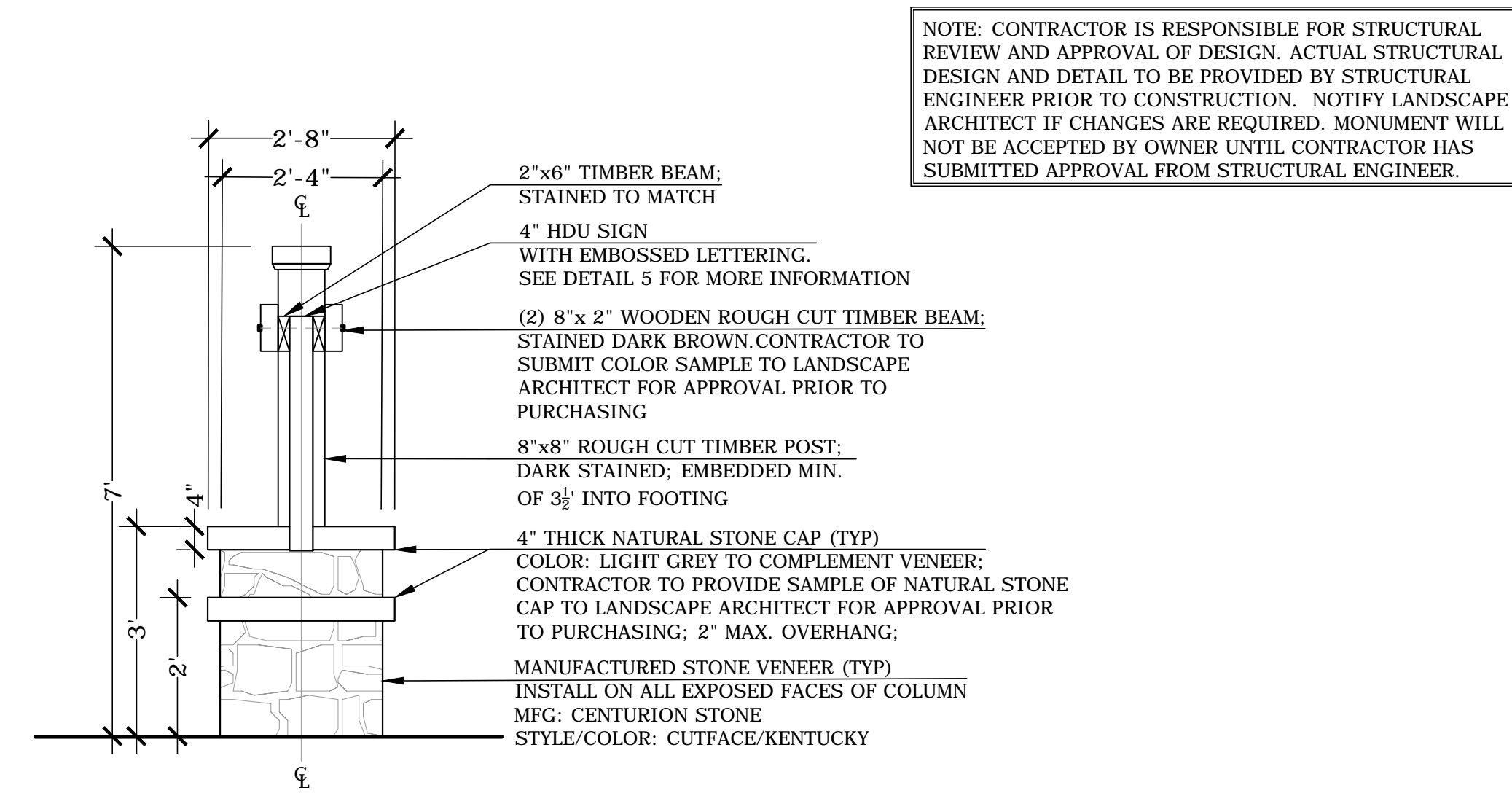

4 MONUMENT ELEVATION - SIDE
SCALE: 1/2" = 1'

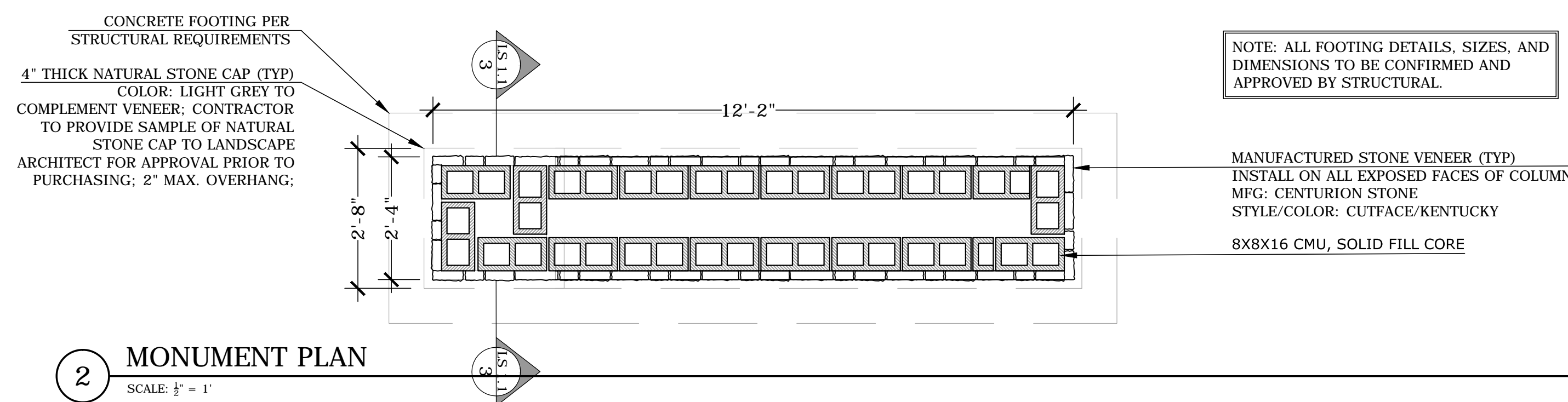

2 MONUMENT PLAN
SCALE: 1/2" = 1'

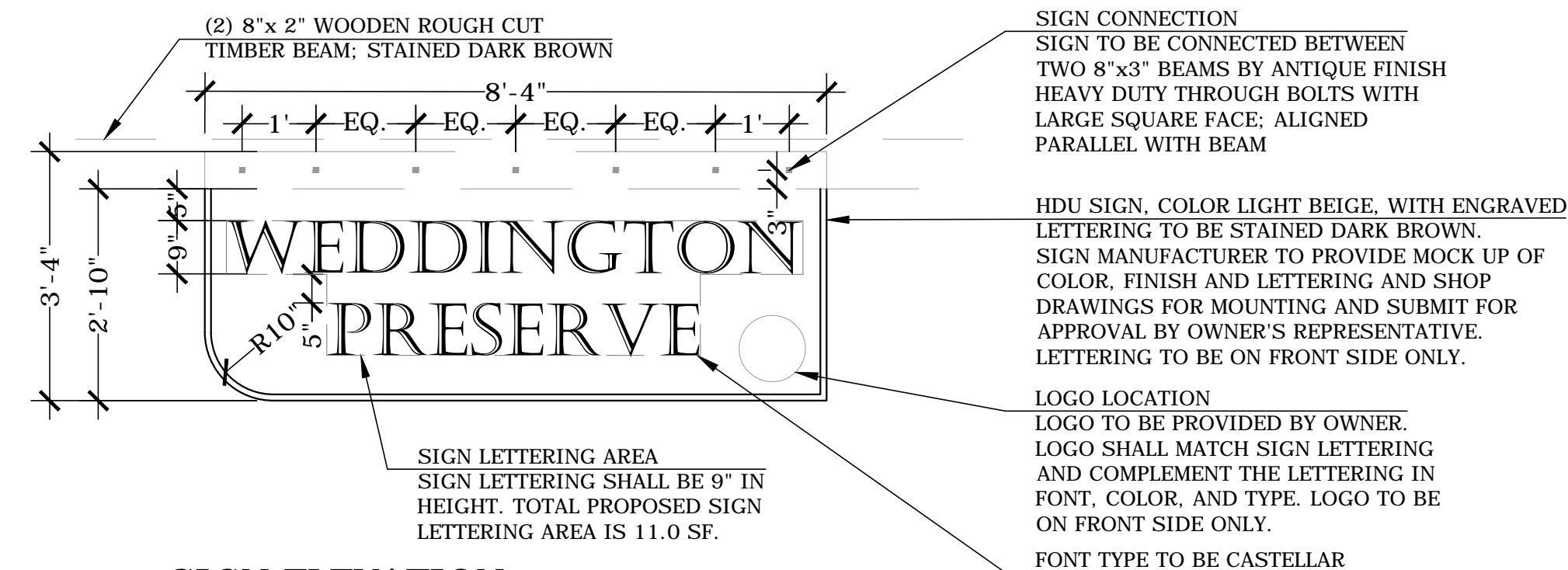

5 SIGN ELEVATION
SCALE: 1/2" = 1'

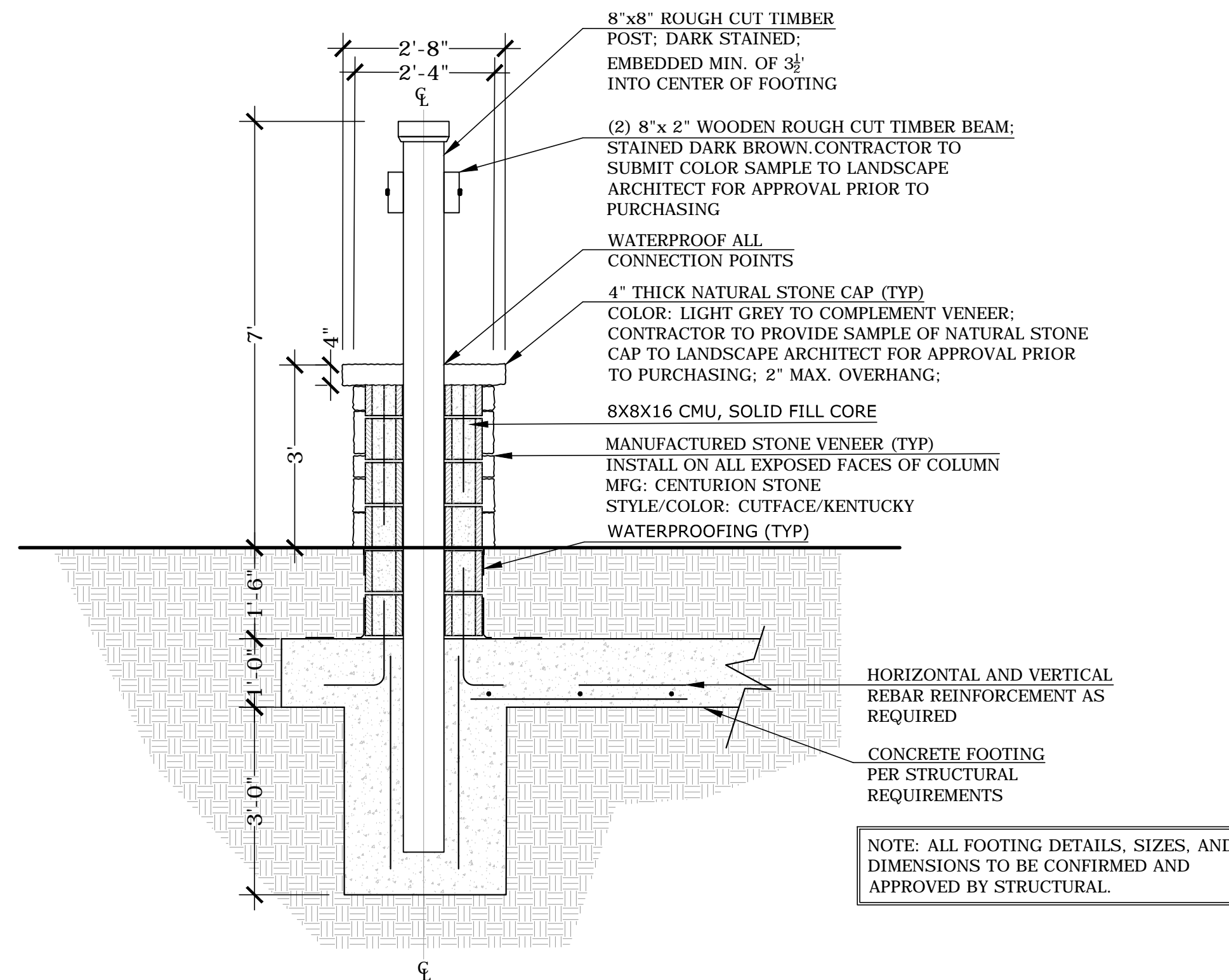

3 COLUMN SECTION
SCALE: 1/2" = 1'

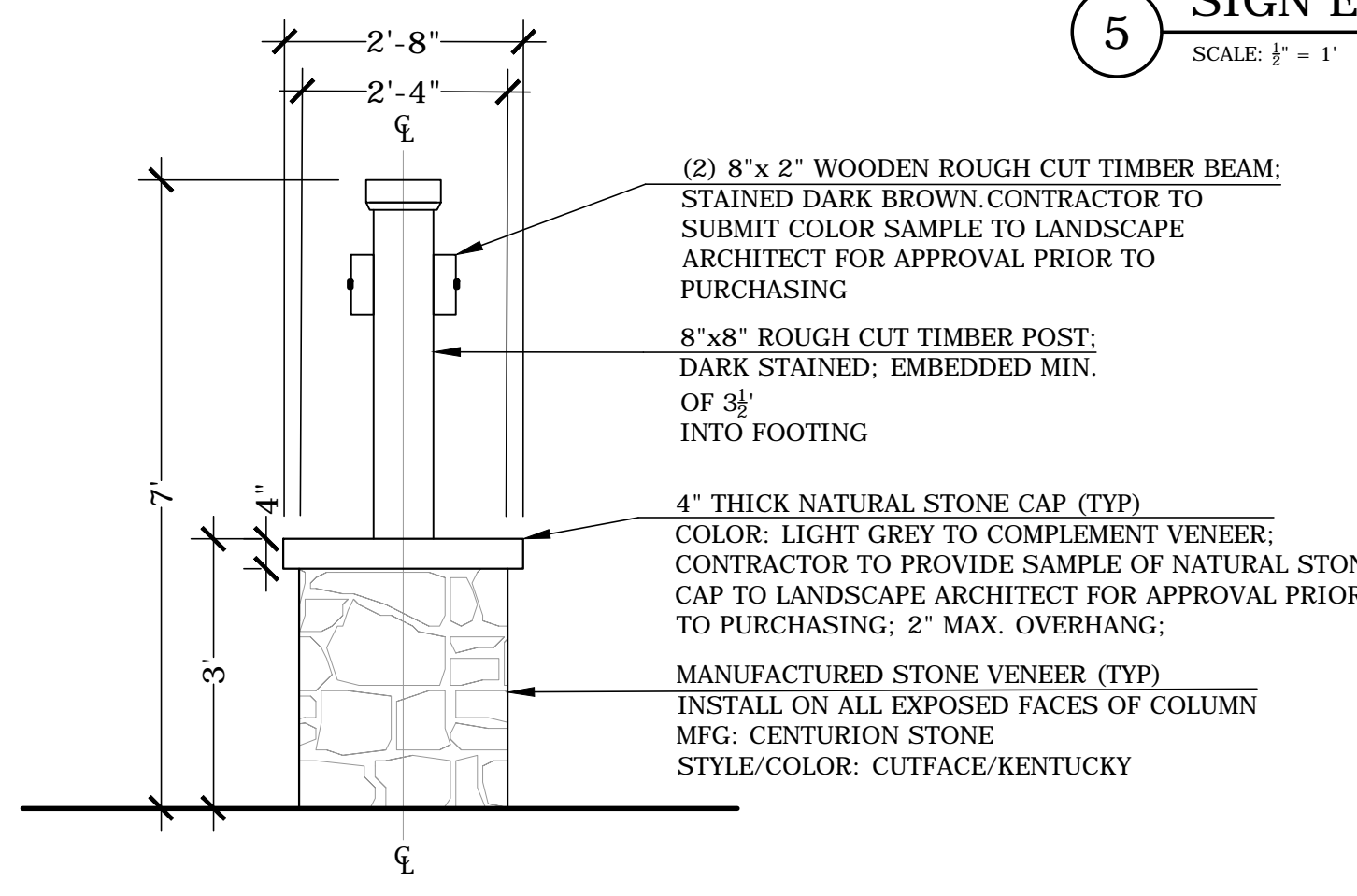

6 COLUMN ELEVATION
SCALE: 1/2" = 1'

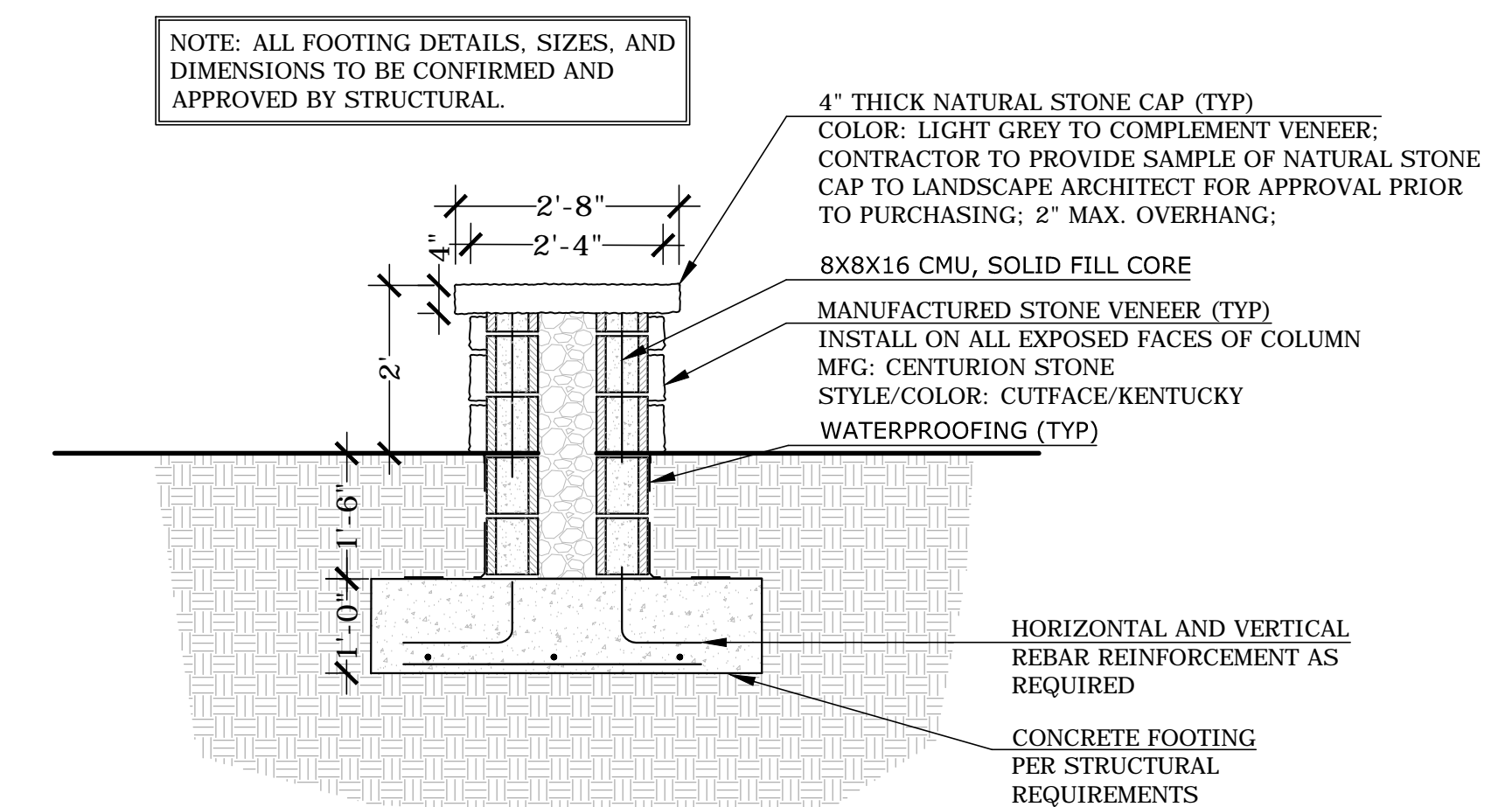

7 WALL SECTION
SCALE: 1/2" = 1'

#	DATE	DESCRIPTION

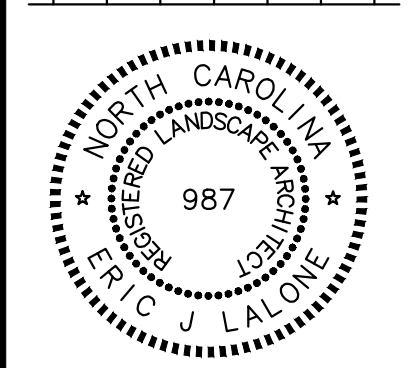

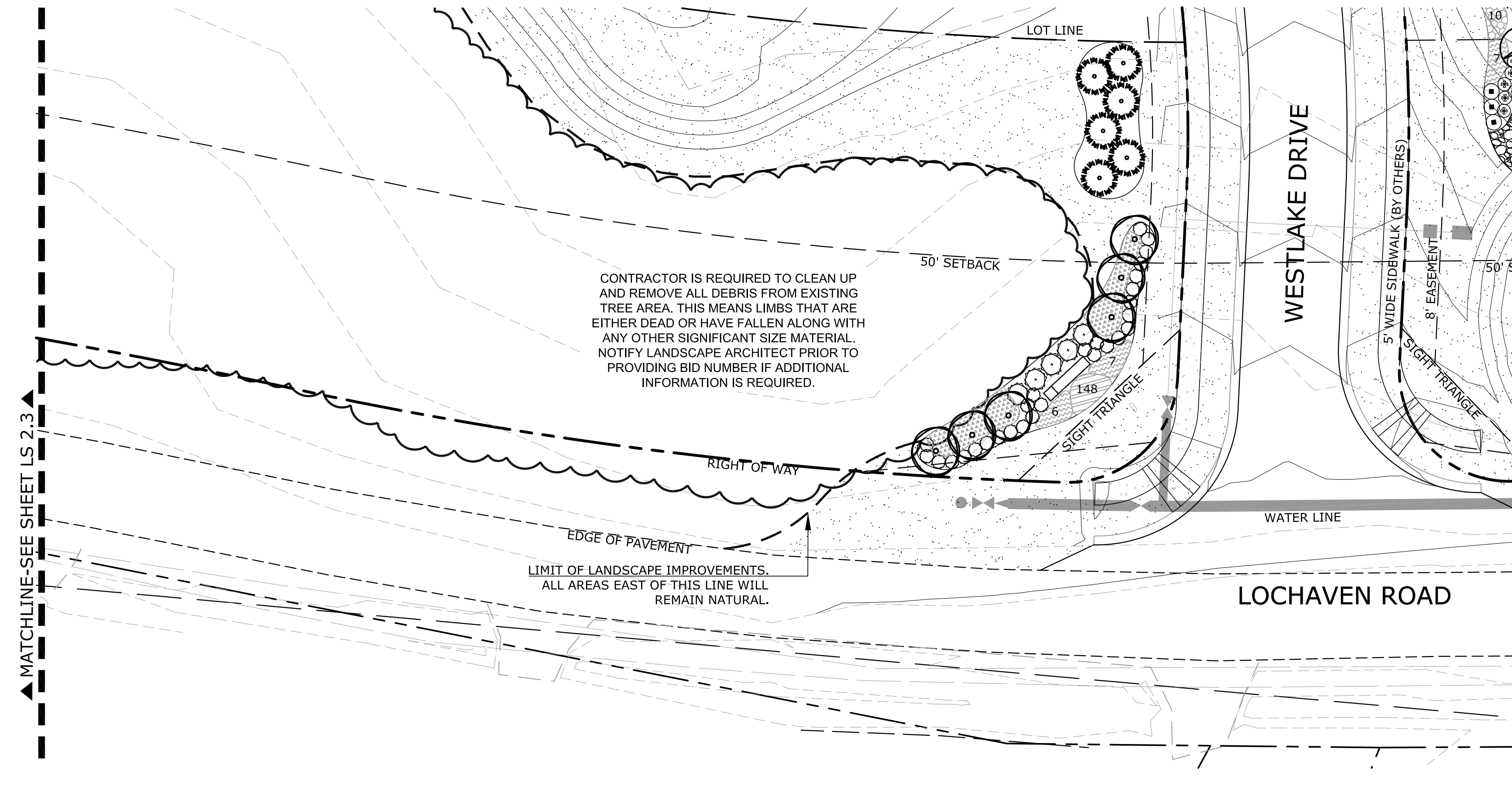

PLANT MATERIALS SCHEDULE

COMMON NAME	BOTANICAL NAME	SIZE	SPACING	MIN. HT.	SYM.	COMMON NAME	BOTANICAL NAME	SIZE	SPACING		
TREES											
WILLOW OAK	QUERCUS PHELLOS	3" CAL.	AS SHOWN	10' HT.		GROUNDCOVERS					
OCTOBER GLORY MAPLE	ACER RUBRUM 'OCTOBER GLORY'	2" CAL.	AS SHOWN			SEASONAL COLOR/ ANNUALS BASED ON TIME OF YEAR. ASSUME 8" SPACING					
KWANZAN CHERRY	PRUNUS SERRULATA 'KWANZAN'	2.5" CAL.	AS SHOWN				DWARF MAIDEN GRASS	MISCANTHUS SINENSIS 'YAKUSHIMA'	1 GAL.	2'-0" O.C.	
LEYLAND CYPRESS	CUPRESSOCYPARIS LEYLANDII	10' HT.	10'-0" O.C.					ZEBRA GRASS	MISCANTHUS SINENSIS 'ZEBRINUS'	1 GAL.	3'-0" O.C.
EMILY BRUNNER HOLLY	ILEX X 'EMILY BRUNNER'	8' HT.	10'-0" O.C.					HIMALAYAN SWEET BOX	SARCOCOCCA HOOKERANA 'HUMILIS'	3 GAL.	3'-6" O.C.
EASTERN RED CEDAR	JUNIPERUS VIRGINIANA	8' HT.	AS SHOWN					MOUNTAIN FIRE PIERIS	PIERIS JAPONICA 'MOUNTAIN FIRE'	3 GAL.	4'-0" O.C.
EMERALD GREEN ARBORVITAE	THUJA OCCIDENTALIS 'SMARAGD'	6' HT.	AS SHOWN					SPREADING JAPANESE PLUM YEW	CERHALOTAXUS HARRINGTONIA 'PROSTRATA'	3 GAL.	2'-6" O.C.
SHRUBS											
FRAGRANT TEA OLIVE	OSMANTHUS FRAGRANS	3 GAL.	AS SHOWN					NUMBER INDICATED ON HATCH THROUGHOUT THE DRAWING REFLECTS THE NUMBER OF PLANTS IN THAT PARTICULAR AREA.			
DWARF YAUPON HOLLY	ILEX VOMITORIA 'NANA'	3 GAL.	3'-0" O.C.					SOD/SEED	FESCUE SOD		
DWARF BURNING BUSH	EUONYMUS ALATA 'COMPACTA'	3 GAL.	3'-0" O.C.					STRAW MULCH			
RUBY LOROPETALUM	LOROPETALUM CHINENSIS 'RUBY'	3 GAL.	3'-0" O.C.					NOTE ALL SHRUB BEDS SHALL CONTAIN A 4" LAYER OF PINE NEEDLE MULCH TYP.			
ROSE CREEK ABELIA	ABELIA X 'ROSE CREEK'	3 GAL.	3'-0" O.C.					ALL ANNUAL BEDS SHALL CONTAIN A 2" MIN LAYER OF SOIL CONDITIONER (FINELY SHREDDED HARDWOODS WITH ORGANICS)			
OTHER LANDSCAPE MATERIAL											
RIVER STONE (SEE PLAN FOR DETAILED INFORMATION)											

TOWN OF WEDDINGTON

MEMORANDUM

TO: Bill Deter, Mayor; Town Council
FROM: Julian Burton; Town Planner/Zoning Administrator
DATE: February 8th, 2016
SUBJECT: Update from the Town Planner

- Rea Road Extension – Public Hearing was held on January 26th.
 - Written comments may still be submitted to NCDOT until the end of February.

SUBDIVISIONS

- Carrington
 - Staff administratively approved a revised Sketch Plan that met the conditions placed on the sketch plan by the Planning Board.
 - Move at least 6 lots from the west side to the east side, and decrease visual density on the west side of Weddington-Matthews Road.
- The Falls at Weddington Amenity Center Construction Documents
 - Rezoning approved at the November 14th, 2015 Town Council meeting.
 - CDs submitted to Town Staff and awaiting review from the Town Engineer.

CRITICAL INTERSECTION ANALYSIS

- The Advisory Committee met on January 27th.
- There were over 50 submittals from the different municipalities, the County, and the UC school board, and the consultants had to use very general data to narrow it down to a preliminary list before ultimately selecting 15 intersections. Unfortunately, the data used did not support the selection of any of the 5 intersections submitted by the Town. However, there was significant discussion regarding the traffic along Providence Road, and staff was able to submit the intersection, Ennis Road and Providence Road, for further study and possible inclusion in the final list of 15.
- The Advisory Committee will meet again in March to discuss the final list of 15 intersections and the potential improvements for each intersection.

WEDDINGTON CODE ENFORCEMENT REPORT

January 28, 2016

1. 404 Cottonfield Cir., James & Shannon Cox

- Wrecked car and inoperative pickup truck parked in side yard and visible from both streets
- Hearing scheduled and held at Town Hall. Owner and wife attended. Vehicles removed/relocated. 2/5/15
- Stockade style fence has been extended to screen side yard from view from front of property; vehicles disposed or relocated?; will continue to monitor—3/15/15
- 6/3/15---- Received email from Julian and website address and advertisement Mr. Cox is running on internet advertising his motor rebuilding business. 8 vehicles and enclosed trailer parked in driveway at this property
- 7/6/15----Issued citation with fine effective 7/10/15
- 8/3/15----5 vehicles in driveway, garage door closed, gate closed.
- 9/3/15----Town attorney to issue a "Cease and desist" letter to Cox.
- 9/9/15----5 vehicles in drive, garage door closed; gate closed.
- 9/16/15-----Attorney (Odom) called on behalf of Cox. Informed him that property is in violation of Zoning Ordinance and must be brought in to compliance to avoid legal action by Town to obtain compliance.
- 10/15/15----Violation continues
- Legal Action underway from the Town Attorney. Have asked for evidence that business has moved to a new location.

2. 6900 Tree Hill Rd., Mark and Nicole Conners

- Complaint that owners have chicken house on property
- 10/9/15---inspected property. No real chicken house, but they do have several chickens, that per owner are children's pets. Will speak with J. Burton about this.
- 1/13/15—Confirmed that chickens removed from property.

3. Lochaven Rd., Douglas and Xan McDowell

- Carpet and carpet padding illegally dumped on this property.
- Sent courtesy letter to owner seeking removal of debris on 12/2/15. No response yet.
- 1/8/16—property cleaned up/trash removed from property.

4. 2101 Eagle Pass Ct., Richard Mrugalski, Jr.

- Electrical contractor business operating from home
- Owner is moving business to commercial space (first of Feb., 2016)
- Town Staff received a copy of a lease indicating that business has moved to a new location outside Weddington.
- Will continue to monitor property to ensure that violation has ceased.

5. Bradshaw property, Matthews-Weddington Rd.

- Old/inoperative farm equipment stored on this property
- 1/26/16—tractors and most equipment has been removed.
- Will continue to monitor this one for removal of all old equipment.

**TOWN OF WEDDINGTON
REVENUE & EXPENDITURE STATEMENT BY DEPARTMENT**

FY 2015-2016

01/01/2016 TO 01/31/2016

	<u>CURRENT PERIOD</u>	<u>YEAR-TO-DATE</u>	<u>BUDGETED</u>	<u>% BUDGET REM</u>
REVENUE:				
10-3101-110 AD VALOREM TAX - CURRENT	122,212.31	941,636.71	944,000.00	0
10-3102-110 AD VALOREM TAX - 1ST PRIOR	258.70	1,516.22	4,000.00	62
10-3103-110 AD VALOREM TAX - NEXT 8	480.05	4,116.21	1,500.00	-174
10-3110-121 AD VALOREM TAX - MOTOR	7,190.73	44,685.56	73,075.00	39
10-3115-180 TAX INTEREST	527.11	939.26	2,250.00	58
10-3231-220 LOCAL OPTION SALES TAX REV	22,763.45	122,818.31	285,000.00	57
10-3322-220 BEER & WINE TAX	0.00	0.00	41,000.00	100
10-3324-220 UTILITY FRANCHISE TAX	0.00	304,111.02	425,000.00	28
10-3340-400 ZONING & PERMIT FEES	7,987.50	28,247.50	25,000.00	-13
10-3350-400 SUBDIVISION FEES	4,400.00	50,180.00	55,000.00	9
10-3830-891 MISCELLANEOUS REVENUES	400.00	968.00	1,000.00	3
10-3831-491 INVESTMENT INCOME	0.00	1,651.98	5,000.00	67
TOTAL REVENUE	<u>166,219.85</u>	<u>1,500,870.77</u>	<u>1,861,825.00</u>	<u>19</u>
AFTER TRANSFERS	<u>166,219.85</u>	<u>1,500,870.77</u>	<u>1,861,825.00</u>	
4110 GENERAL GOVERNMENT				
EXPENDITURE:				
10-4110-126 FIRE DEPT SUBSIDIES	58,288.75	411,570.93	709,895.00	42
10-4110-127 FIRE DEPARTMENT	0.00	3,642.15	3,800.00	4
10-4110-128 POLICE PROTECTION	61,764.00	185,813.44	248,677.00	25
10-4110-192 ATTORNEY FEES - GENERAL	7,322.44	34,343.32	95,000.00	64
10-4110-193 ATTORNEY FEES - LITIGATION	-7,322.44	92,090.22	84,000.00	-10
10-4110-195 ELECTION EXPENSE	8,871.58	8,871.58	11,000.00	19
10-4110-340 EVENTS & PUBLICATIONS	0.00	787.95	12,000.00	93
10-4110-341 WEDDINGTON FESTIVAL	0.00	-3,130.28	5,000.00	163
10-4110-342 HOLIDAY/TREE LIGHTING	1,050.00	4,084.62	6,500.00	37
10-4110-343 EASTER EGG HUNT	-489.32	-489.32	750.00	165
10-4110-344 OTHER COMMUNITY EVENTS	0.00	138.53	2,250.00	94
TOTAL EXPENDITURE	<u>129,485.01</u>	<u>737,723.14</u>	<u>1,178,872.00</u>	<u>37</u>
BEFORE TRANSFERS	<u>-129,485.01</u>	<u>-737,723.14</u>	<u>-1,178,872.00</u>	
AFTER TRANSFERS	<u>-129,485.01</u>	<u>-737,723.14</u>	<u>-1,178,872.00</u>	
4120 ADMINISTRATIVE				
EXPENDITURE:				
10-4120-121 SALARIES - CLERK	5,966.66	41,599.96	71,000.00	41
10-4120-123 SALARIES - TAX COLLECTOR	3,328.08	23,945.96	46,315.00	48
10-4120-124 SALARIES - FINANCE OFFICER	830.82	6,424.88	13,840.00	54
10-4120-125 SALARIES - MAYOR & TOWN	2,100.00	14,700.00	25,200.00	42
10-4120-181 FICA EXPENSE	935.19	6,622.39	12,460.00	47
10-4120-182 EMPLOYEE RETIREMENT	1,371.01	9,586.46	18,885.00	49
10-4120-183 EMPLOYEE INSURANCE	2,088.00	13,574.13	25,000.00	46

TOWN OF WEDDINGTON
REVENUE & EXPENDITURE STATEMENT BY DEPARTMENT

FY 2015-2016

01/01/2016 TO 01/31/2016

	<u>CURRENT PERIOD</u>	<u>YEAR-TO-DATE</u>	<u>BUDGETED</u>	<u>% BUDGET REM</u>
10-4120-184 EMPLOYEE LIFE INSURANCE	30.24	192.36	400.00	52
10-4120-185 EMPLOYEE S-T DISABILITY	24.00	168.00	300.00	44
10-4120-191 AUDIT FEES	0.00	0.00	8,500.00	100
10-4120-193 CONTRACT LABOR	0.00	0.00	11,430.00	100
10-4120-200 OFFICE SUPPLIES - ADMIN	330.06	2,737.91	12,500.00	78
10-4120-210 PLANNING CONFERENCE	0.00	0.00	2,500.00	100
10-4120-321 TELEPHONE - ADMIN	270.47	1,294.43	3,500.00	63
10-4120-325 POSTAGE - ADMIN	150.00	1,025.93	2,500.00	59
10-4120-331 UTILITIES - ADMIN	506.78	2,169.23	4,250.00	49
10-4120-351 REPAIRS & MAINTENANCE -	0.00	7,900.00	30,223.00	74
10-4120-352 REPAIRS & MAINTENANCE -	4,724.57	48,418.08	63,000.00	23
10-4120-354 REPAIRS & MAINTENANCE -	-1,430.15	23,669.85	57,250.00	59
10-4120-355 REPAIRS & MAINTENANCE -	110.00	330.00	1,000.00	67
10-4120-356 REPAIRS & MAINTENANCE -	0.00	2,200.00	6,000.00	63
10-4120-370 ADVERTISING - ADMIN	39.10	528.26	1,000.00	47
10-4120-397 TAX LISTING & TAX	55.00	-314.86	1,000.00	131
10-4120-400 ADMINISTRATIVE:TRAINING	0.00	2,673.95	4,000.00	33
10-4120-410 ADMINISTRATIVE:TRAVEL	868.20	2,322.65	6,000.00	61
10-4120-450 INSURANCE	0.00	13,387.05	15,500.00	14
10-4120-491 DUES & SUBSCRIPTIONS	125.00	14,445.00	18,000.00	20
10-4120-498 GIFTS & AWARDS	29.73	1,978.34	3,500.00	43
10-4120-499 MISCELLANEOUS	725.29	2,698.83	5,000.00	46
TOTAL EXPENDITURE	23,178.05	244,278.79	470,053.00	48

BEFORE TRANSFERS	-23,178.05	-244,278.79	-470,053.00
------------------	------------	-------------	-------------

AFTER TRANSFERS	-23,178.05	-244,278.79	-470,053.00
-----------------	------------	-------------	-------------

4130 PLANNING & ZONING

EXPENDITURE:

10-4130-121 SALARIES - ZONING	4,570.10	32,805.24	57,240.00	43
10-4130-122 SALARIES - ASST ZONING	106.08	770.94	2,250.00	66
10-4130-123 SALARIES - RECEPTIONIST	1,627.12	12,085.76	24,975.00	52
10-4130-124 SALARIES - PLANNING BOARD	425.00	2,775.00	5,200.00	47
10-4130-125 SALARIES - SIGN REMOVAL	222.74	1,801.82	4,000.00	55
10-4130-181 FICA EXPENSE - P&Z	531.79	3,847.23	7,770.00	50
10-4130-182 EMPLOYEE RETIREMENT - P&Z	914.07	6,455.78	13,015.00	50
10-4130-183 EMPLOYEE INSURANCE	2,088.00	14,616.00	27,000.00	46
10-4130-184 EMPLOYEE LIFE INSURANCE	20.44	143.08	300.00	52
10-4130-185 EMPLOYEE S-T DISABILITY	12.00	84.00	150.00	44
10-4130-193 CONSULTING	-1,686.90	-14,199.50	10,000.00	242
10-4130-194 CONSULTING - COG	3,900.00	11,700.00	21,750.00	46
10-4130-200 OFFICE SUPPLIES - PLANNING	330.06	2,627.62	5,000.00	47
10-4130-201 ZONING SPECIFIC OFFICE	0.00	40.01	2,500.00	98
10-4130-215 HISTORIC PRESERVATION	0.00	0.00	2,500.00	100
10-4130-220 TRANSPORTATION &	0.00	0.00	18,000.00	100

TOWN OF WEDDINGTON
REVENUE & EXPENDITURE STATEMENT BY DEPARTMENT

FY 2015-2016

01/01/2016 TO 01/31/2016

	<u>CURRENT PERIOD</u>	<u>YEAR-TO-DATE</u>	<u>BUDGETED</u>	<u>% BUDGET REM</u>
10-4130-321 TELEPHONE - PLANNING &	270.49	1,294.52	3,500.00	63
10-4130-325 POSTAGE - PLANNING & ZONING	150.00	875.54	2,500.00	65
10-4130-331 UTILITIES - PLANNING & ZONING	506.79	2,169.24	4,250.00	49
10-4130-370 ADVERTISING - PLANNING &	39.10	356.10	1,000.00	64
TOTAL EXPENDITURE	<u>14,026.88</u>	<u>80,248.38</u>	<u>212,900.00</u>	<u>62</u>
BEFORE TRANSFERS	<u>-14,026.88</u>	<u>-80,248.38</u>	<u>-212,900.00</u>	
AFTER TRANSFERS	<u>-14,026.88</u>	<u>-80,248.38</u>	<u>-212,900.00</u>	
GRAND TOTAL	<u><u>-470.09</u></u>	<u><u>438,620.46</u></u>	<u><u>0.00</u></u>	

TOWN OF WEDDINGTON
BALANCE SHEET

FY 2015-2016

PERIOD ENDING: 01/01/2016

10

ASSETS

ASSETS

10-1120-000	TRINITY CHECKING ACCOUNT	1,164,253.48
10-1120-001	TRINITY MONEY MARKET	1,107,703.63
10-1170-000	NC CASH MGMT TRUST	530,325.89
10-1211-001	A/R PROPERTY TAX	163,971.91
10-1212-001	A/R PROPERTY TAX - 1ST YEAR PRIOR	5,528.34
10-1212-002	A/R PROPERTY TAX - NEXT 8 PRIOR YRS	12,218.91
10-1232-000	SALES TAX RECEIVABLE	1,237.00
10-1610-001	FIXED ASSETS - LAND & BUILDINGS	1,753,018.11
10-1610-002	FIXED ASSETS - FURNITURE & FIXTURES	23,513.12
10-1610-003	FIXED ASSETS - EQUIPMENT	118,306.60
10-1610-004	FIXED ASSETS - INFRASTRUCTURE	26,851.01
TOTAL ASSETS		4,906,928.00

LIABILITIES & EQUITY

LIABILITIES

10-2120-000	BOND DEPOSIT PAYABLE	71,897.25
10-2620-000	DEFERRED REVENUE - DELQ TAXES	5,528.34
10-2625-000	DEFERRED REVENUE - CURR YR TAX	163,971.91
10-2630-000	DEFERRED REVENUE-NEXT 8	12,218.91
TOTAL LIABILITIES		253,616.41

EQUITY

10-2620-001	FUND BALANCE - UNASSIGNED	2,416,690.89
10-2620-003	FUND BALANCE-ASSIGNED	236,000.00
10-2620-004	FUND BALANCE-INVEST IN FIXED ASSETS	1,921,688.84
10-2620-005	CURRENT YEAR EQUITY YTD	-360,158.69
CURRENT FUND BALANCE - YTD NET REV		439,090.55
TOTAL EQUITY		4,653,311.59

TOTAL LIABILITIES & FUND EQUITY	4,906,928.00
---------------------------------	--------------

TOWN OF WEDDINGTON

MEMORANDUM

TO: Mayor and Town Council

FROM: Kim Woods, Tax Collector

DATE: February 8, 2016

SUBJECT: Monthly Report –January 2016

Transactions:	
Adjustment under \$5.00	\$(90.12)
Balance Adjustments	\$(31.44)
Interest Charges	\$1387.15
Overpayments	\$(31.20)
Penalty & Interest Payments	\$(562.21)
Discoveries	\$172.54
Releases	\$(21.68)
Refunds	\$194.02
Taxes Collected:	
2012	\$(252.96)
2013	\$(258.70)
2014	\$(258.70)
2015	\$(123207.91)
As of January 31, 2016; the following taxes remain Outstanding:	
2005	\$252.74
2006	\$56.80
2007	\$93.78
2008	\$1039.45
2009	\$865.35
2010	\$729.72
2011	\$463.55
2012	\$4025.53
2013	\$4114.85
2014	\$5223.10
2015	\$42146.35
Total Outstanding:	\$59011.22

FY 2015-2016

TOWN OF WEDDINGTON
 UNPAID BALANCE REPORT BY RECEIPT NUMBER
 TAX YEARS 2015 TO 2015

UNPAID AS OF 02/02/2016

<u>NAME</u>	<u>REC NO</u>	<u>MAP NUMBER/ID</u>	<u>REAL</u>	<u>PERSONAL</u>	<u>MERCHANT</u>	<u>UTILITIES</u>	<u>TOTAL</u>	<u>INTEREST</u>
TAX YEAR: 2015								
CHERRY HOMES LLC	1	06041002	50.82				50.82	
CHERRY HOMES LLC	9	06042005	50.93				50.93	
TURNER ROBBIE	32	06042098	185.06				185.06	
HELMS RICKY D	47	06042124	82.62				82.62	
PEARSON CALVIN LEE	68	06063032	133.22				133.22	
MAUST KEITH P	99	06063100	199.11				199.11	
PRICE ALTON A JR	115	06063121	8.55				8.55	
PRICE ALTON A JR	116	06063122	8.65				8.65	
PRICE ALTON A JR	117	06063123	8.55				8.55	
HARRELL R DEAN TRUSTEE	150	06066006B	5.05				5.05	
COLLINS FRANCES W	153	06066008	241.28				241.28	
REED RUSSELL MANN	176	06066052	53.28				53.28	
WALLS RICKEY L	179	06066056	190.82				190.82	
TURPIN SONJA L UPCHURCH	192	06066084	372.41				372.41	
MCRAE INEZ B TRUST THE	223	06066139	179.45				179.45	
KIRK JOHN B	244	06066193	150.48				150.48	
GRAHAM MELVIN F TRUSTEE	248	06066197	36.12				36.12	
GRAHAM MELVIN F TRUSTEE	249	06066198	6.52				6.52	
SMITH MILES O	257	06066209	31.80				31.80	
NEXIUS LLC AND STEVENS	261	06066217	48.41				48.41	
PRUITT ANDREW J	274	06066242	219.36				219.36	

FY 2015-2016

TOWN OF WEDDINGTON
 UNPAID BALANCE REPORT BY RECEIPT NUMBER
 TAX YEARS 2015 TO 2015

UNPAID AS OF 02/02/2016

<u>NAME</u>	<u>REC NO</u>	<u>MAP NUMBER/ID</u>	<u>REAL</u>	<u>PERSONAL</u>	<u>MERCHANT</u>	<u>UTILITIES</u>	<u>TOTAL</u>	<u>INTEREST</u>
CHERRY HOMES INC	277	06066248	5.87				5.87	
HANCOCK LILLIE O	298	06069003	90.26				90.26	
WULF BRIAN K	336	06069128	149.31				149.31	
PATCH BRANSEN	354	06069162	273.28				273.28	
SERGEANT ROBERT L	372	06069204A	15.33				15.33	
SERGEANT ROBERT L	380	06069223	40.56				40.56	
PRITT GARY D	411	06072043	167.15				167.15	
HOLLINGSWORTH CRYSTAL C	448	06090030	29.56				29.56	
RUSSELL BENJAMIN	450	06090032	38.04				38.04	
WALTER GEORGE ALBERT	461	06093006	148.61				148.61	
RIVER BIRCH LAND TRUST	497	06093063	26.35				26.35	
ELLISON TIMOTHY SCOTT	509	06093103	5.73				5.73	
WATT LINDA ANN TRUSTEE	520	06093121	368.61				368.61	
KISER PATTY R	548	06096004	103.93				103.93	
MORRIS BRYAN STEVEN	561	06096020D	39.87				39.87	
KILBOURNE GINGER	575	06096033A	28.85				28.85	
KERRIGAN MICHAEL J	588	06096056	92.13				92.13	
JACKSON STEVEN L	599	06096077	13.63				13.63	
SEXTON MICHAEL C	603	06096083	92.61				92.61	
BLOCK TERRI T	623	06096149	29.23				29.23	
STEVENS MARC G	641	06096187	158.55				158.55	
CALDWELL DEIRDRE B	652	06096217	258.91				258.91	

FY 2015-2016

TOWN OF WEDDINGTON
 UNPAID BALANCE REPORT BY RECEIPT NUMBER
 TAX YEARS 2015 TO 2015

UNPAID AS OF 02/02/2016

<u>NAME</u>	<u>REC NO</u>	<u>MAP NUMBER/ID</u>	<u>REAL</u>	<u>PERSONAL</u>	<u>MERCHANT</u>	<u>UTILITIES</u>	<u>TOTAL</u>	<u>INTEREST</u>
PARSONS MEMORY SHAE	675	06096273	387.80				387.80	
BLACK ROBERT D &	697	06096314	8.86				8.86	
HUNTER GARY MICHAEL	703	06096322	52.80				52.80	
NOLAN WILLIAM J	707	06099004P	10.11				10.11	
TAYLOR RYAN A	712	06099008A	129.00				129.00	
MURRAY KEVIN D	733	06099016C	114.04				114.04	
MCWILLIAMS DREW MICHAEL	737	06099017D	59.31				59.31	
NICHOLS WESLEY C	738	06099018	132.69				132.69	
HOWSON JULIE M	799	06099156	55.47				55.47	
SCHUSTER GREGORY L	832	06099233	295.51				295.51	
PENSABENE DOMINICK	836	06099240	283.27				283.27	
HERBST JEFFREY D	842	06099258	258.47				258.47	
BALDWIN CORY G	890	06099395	257.94				257.94	
PARKER & ORLEANS	892	06099406	49.70				49.70	
PRODDATURU MITHUN REDDY	902	06099419	49.70				49.70	
LEMMOND DAVID M	926	06102014	178.70				178.70	
PERI CHANDRA S	940	06102366	353.17				353.17	
GUION WADE E	950	06117002	47.39				47.39	
AIDEN PROPERTIES LLC	954	06117005	83.41				83.41	
AIDEN PROPERTIES LLC	955	06117005A	148.78				148.78	
HAUGHWOUT PAUL C	975	06117054	252.55				252.55	
SOUTHARD VAN	1061	06117227	335.59				335.59	

FY 2015-2016

TOWN OF WEDDINGTON
 UNPAID BALANCE REPORT BY RECEIPT NUMBER
 TAX YEARS 2015 TO 2015

UNPAID AS OF 02/02/2016

<u>NAME</u>	<u>REC NO</u>	<u>MAP NUMBER/ID</u>	<u>REAL</u>	<u>PERSONAL</u>	<u>MERCHANT</u>	<u>UTILITIES</u>	<u>TOTAL</u>	<u>INTEREST</u>
HERITAGE VENTURES INC	1075	06117256	52.90				52.90	
MATTHEWS BUILDING SUPPLY	1082	06117267	70.54				70.54	
PARKER & ORLEANS	1103	06117310	66.80				66.80	
WATTERSON RONALD K	1185	06120085	197.14				197.14	
CALDWELL RICHARD D	1204	06120120	5.42				5.42	
PINACCLE HOMES USA LLC	1218	06120149	36.50				36.50	
GETTYS HOME BUILDERS INC	1275	06120264	14.59				14.59	
GETTYS CONSTRUCTION CO	1276	06120265	19.07				19.07	
WILLIAMSON MICHAEL	1297	06123004C	139.69				139.69	
GRANGER MAURICE DAVID	1326	06123050	178.43				178.43	
LEONID FIMOVICH	1327	06123054	189.65				189.65	
LOWE NANCY CHERYL	1338	06123080	47.88				47.88	
BLUE JAY INVESTMENTS LLC	1358	06123127A	66.75				66.75	
NOLAN WILLIAM J III	1365	06123150	13.15				13.15	
LEMMETTI JACQUES M	1380	06123183	358.73				358.73	
IB DEVELOPMENT LLC	1431	06126002	2,392.84				2,392.84	
WEDDINGTON BTS	1438	06126006A	1,028.84				1,028.84	
IB DEVELOPMENT LLC	1442	06126010	93.68				93.68	
IB DEVELOPMENT LLC	1443	06126010A	9.25				9.25	
IB DEVELOPMENT LLC	1444	06126010B	309.78				309.78	
IB DEVELOPMENT LLC	1445	06126011	28.69				28.69	
HONEYCREEK INC	1447	06126015	89.73				89.73	

FY 2015-2016

TOWN OF WEDDINGTON
 UNPAID BALANCE REPORT BY RECEIPT NUMBER
 TAX YEARS 2015 TO 2015

UNPAID AS OF 02/02/2016

<u>NAME</u>	<u>REC NO</u>	<u>MAP NUMBER/ID</u>	<u>REAL</u>	<u>PERSONAL</u>	<u>MERCHANT</u>	<u>UTILITIES</u>	<u>TOTAL</u>	<u>INTEREST</u>
BRIGMAN JEANNETTE	1448	06126015B	73.83				73.83	
BRIGMAN JEANNETTE	1450	06126015H	8.02				8.02	
HONEYCREEK INC	1456	06126019	25.02				25.02	
HONEYCREEK INC	1459	06126024	34.95				34.95	
WATSON CHARLES THOMAS	1467	06126043	147.59				147.59	
WATSON CHARLES THOMAS	1468	06126045	18.97				18.97	
HONEYCREEK INC	1469	06126046	8.23				8.23	
MCLEOD CAROLE MOORE	1520	06129053	397.74				397.74	
O'BRIEN MICHAEL	1540	06129089	669.04				669.04	
WHIPPLE DORRIS WM	1541	06129090	293.86				293.86	
O'BRIEN MICHAEL T	1557	06129115A	29.71				29.71	
O'BRIEN MICHAEL T	1559	06129117	29.44				29.44	
O'BRIEN MICHAEL	1560	06129118	13.73				13.73	
O'BRIEN MICHAEL T	1561	06129120	25.07				25.07	
MORRISON HENDERSON JR	1563	06132001A	29.92				29.92	
SIMS CURL W JR	1565	06132001C	12.39				12.39	
MORRISON STEPHEN	1566	06132001D	44.52				44.52	
MORRISON SAMUEL ELLIOTT	1567	06132001F	125.64				125.64	
CHERIAN GEORGE	1569	06132001H	105.32				105.32	
THREATT JAMES HAZEL	1573	06132021	94.00				94.00	
BLUE JAY INVESTMENTS LLC	1590	06147004	116.17				116.17	
BLUE JAY INVESTMENTS LLC	1592	06147004B	164.70				164.70	

FY 2015-2016

TOWN OF WEDDINGTON
 UNPAID BALANCE REPORT BY RECEIPT NUMBER
 TAX YEARS 2015 TO 2015

UNPAID AS OF 02/02/2016

<u>NAME</u>	<u>REC NO</u>	<u>MAP NUMBER/ID</u>	<u>REAL</u>	<u>PERSONAL</u>	<u>MERCHANT</u>	<u>UTILITIES</u>	<u>TOTAL</u>	<u>INTEREST</u>
DOW ROBERT B TRUST	1598	06147008A	195.79				195.79	
ROYAL BOUNTY LLC	1619	06147032	7.62				7.62	
TELLER JASON	1706	06150004	27.74				27.74	
TELLER JASON	1726	06150038	35.22				35.22	
HARDING PETER M	1729	06150041A	27.63				27.63	
M SQUARED HOLDINGS LLC	1751	06150059A	941.47				941.47	
MOORE MARGARET COREY	1752	06150059B	322.60				322.60	
MOORE JAMES LLOYD JR	1753	06150059C	45.74				45.74	
HELMS GERALD CLYDE	1757	06150063	175.44				175.44	
IB DEVELOPMENT LLC	1764	06150071	338.84				338.84	
REA CHRISTOPHER A	1795	06150106	14.22				14.22	
CAROTHERS JEAN C	1797	06150111	165.44				165.44	
CAROTHERS JEAN C	1799	06150115	28.42				28.42	
HARDING PETER MARTIN	1822	06150167	284.61				284.61	
MUEDDER ALLISON BLAIR	1863	06153013D	53.39				53.39	
JOHNSON PAUL	1866	06153014	288.99				288.99	
JOHNSON MICHAEL C	1881	06153034	98.97				98.97	
AIRBORN DEVELOPMENT LLC	1887	06153046	27.09				27.09	
PETROVSKY CARL	1893	06153053	38.53				38.53	
CULBERTSON ROCKY S	1896	06153057	120.24				120.24	
COX JAMES E	1900	06153084	198.95				198.95	
SINGH JATINDER PAL	1901	06153085	151.45				151.45	

FY 2015-2016

TOWN OF WEDDINGTON
 UNPAID BALANCE REPORT BY RECEIPT NUMBER
 TAX YEARS 2015 TO 2015

UNPAID AS OF 02/02/2016

<u>NAME</u>	<u>REC NO</u>	<u>MAP NUMBER/ID</u>	<u>REAL</u>	<u>PERSONAL</u>	<u>MERCHANT</u>	<u>UTILITIES</u>	<u>TOTAL</u>	<u>INTEREST</u>
JANSEN STEPHEN M	1919	06153114	-0.20				-0.20	
DUNN LISA L TRUSTEE	1926	06153126	403.14				403.14	
VORONIN DAVID	1927	06153128	108.53				108.53	
AFT ENTERPRISES INC	1930	06153134	7.37				7.37	
AFT ENTERPRISES INC	1932	06153136	9.72				9.72	
AFT ENTERPRISES INC	1933	06153138	7.70				7.70	
MENZEL PAMELA	1945	06153161	106.18				106.18	
HAMEL REGINALD S TRUSTEE	1950	06153168	462.78				462.78	
EDOSOMWAN FIDELIS	1951	06153169	1,392.00				1,392.00	
WILLIAMS DE'ANGELO	1958	06153177	659.69				659.69	
DAVIS THOMAS	1973	06153201	1,342.35				1,342.35	
BLACK DIAMOND HOMES LLC	1986	06153216	182.86				182.86	
ALHAJLI KAMAL HAMED	1991	06153223	699.45				699.45	
VALENTINE JAMES J	2081	06174059	587.98				587.98	
SAIR FARRUKH	2086	06174065	113.34				113.34	
BENDER NATHAN M	2104	06174098	626.34				626.34	
BROWN WILLIAM T JR	2118	06174118	738.51				738.51	
ROSEPILER MICHAEL J	2175	06174363	107.04				107.04	
EL-GAMAL HAZEM	2183	06174376	694.42				694.42	
LEWIS RICHARD JR	2194	06174389	934.84				934.84	
GHANNAM RAMI AL	2205	06174400	112.75				112.75	
DT SQUARE PROPERTIES LLC	2209	06177007	91.06				91.06	

FY 2015-2016

TOWN OF WEDDINGTON
 UNPAID BALANCE REPORT BY RECEIPT NUMBER
 TAX YEARS 2015 TO 2015

UNPAID AS OF 02/02/2016

<u>NAME</u>	<u>REC NO</u>	<u>MAP NUMBER/ID</u>	<u>REAL</u>	<u>PERSONAL</u>	<u>MERCHANT</u>	<u>UTILITIES</u>	<u>TOTAL</u>	<u>INTEREST</u>
ALMJARKASH MAJD	2295	06180051	324.00				324.00	
TOTARO DENNIS F	2317	06180354	0.06				0.06	
PURDY J SCOTT	2327	06180371	66.80				66.80	
AYADI FAKHER	2329	06180376	459.88				459.88	
TIGANI GREGORY J	2330	06180377	384.53				384.53	
HARRELL RON A	2337	07135061A	110.99				110.99	
NELSON HOWARD M	2370	07138028	220.75				220.75	
HOFFMAN JOHN L S	2401	07138076	125.31				125.31	
MYERS MICHAEL W TRUSTEES	2406	07138082	135.89				135.89	
PRICE TERRELL	2414	07138090	203.16				203.16	
DUFFIN DONALD	2429	07138116	166.99				166.99	
WEDDINGTON INVESTORS II	2468	07150009F	487.04				487.04	
BRAGA EMERSON	2469	07150012A	35.05				35.05	
BRAGA EMERSON	2471	07150012C	30.09				30.09	
BRAGA EMERSON	2472	07150013	76.33				76.33	
WINCHESTER FRANK ORMAND	2473	07150013A	67.82				67.82	
MCDONALD KELLY	2485	07150078	32.86				32.86	
KILGO JAMES W	2521	07153002B	48.84				48.84	
AUTRY PEGGY M	3175	E7150011	83.42				83.42	
AUTRY PEGGY M	3179	F7150011A	158.81				158.81	
BURNS JAMES W & WIFE	6249	06066265	267.72				267.72	
HAWKINS SHAWN A	6252	06066271	226.30				226.30	

FY 2015-2016

TOWN OF WEDDINGTON
 UNPAID BALANCE REPORT BY RECEIPT NUMBER
 TAX YEARS 2015 TO 2015

UNPAID AS OF 02/02/2016

<u>NAME</u>	<u>REC NO</u>	<u>MAP NUMBER/ID</u>	<u>REAL</u>	<u>PERSONAL</u>	<u>MERCHANT</u>	<u>UTILITIES</u>	<u>TOTAL</u>	<u>INTEREST</u>
MANESS JEFFREY A	6283	06069050	152.94				152.94	
ROBINSON EDWARD HARVEY	6331	06069125	210.17				210.17	
TILLEY CHADWICK A	6346	06069156	264.15				264.15	
SOWERS ERIC J & WIFE	6348	06069158	241.91				241.91	
OVENDORF ERIC R	6475	06093108	229.09				229.09	
TRAILL GARRIN G	6480	06093122	366.90				366.90	
JOHNSON RONALD W	6484	06093128	383.41				383.41	
BERG KARIJ	6488	06093136	372.41				372.41	
KANOS DENNIS J	6615	06096198	231.07				231.07	
KANOS DENO J & WIFE	6617	06096200	250.79				250.79	
MCNEIL SAMUEL P JR &	6628	06096221	41.20				41.20	
MCNEIL SAMUEL P JR &	6629	06096222	273.71				273.71	
WOODWARD M BRYAN III	6665	06096286	382.13				382.13	
GAYNOR BLAIR & CAROLYN	6679	06099011A	244.38				244.38	
WRIGHT CHARLES J	6716	06099084	57.18				57.18	
STONE FREDERICK B	6745	06099139	292.63				292.63	
KLINGERMAN JEFFREY A &	6760	06099157	299.73				299.73	
DORTON JAMES W III	6767	06099167	268.89				268.89	
JAMPANI SASIDAR	6824	06099268	286.64				286.64	
TREMBLAY HEIDI S	6888	06099367	242.44				242.44	
TWARAKAVI	6918	06099425	232.14				232.14	
JONES JARRELL K	7077	06117253	327.52				327.52	

FY 2015-2016

TOWN OF WEDDINGTON
UNPAID BALANCE REPORT BY RECEIPT NUMBER
TAX YEARS 2015 TO 2015

UNPAID AS OF 02/02/2016

<u>NAME</u>	<u>REC NO</u>	<u>MAP NUMBER/ID</u>	<u>REAL</u>	<u>PERSONAL</u>	<u>MERCHANT</u>	<u>UTILITIES</u>	<u>TOTAL</u>	<u>INTEREST</u>
HALLE ROBERT F	7332	06123203	392.71				392.71	
JONES BRITT	7345	06126038	14.05				14.05	
COLLINS DAVID	7432	06147092	340.77				340.77	
JP MORGAN CHASE	7614	06153217	182.76				182.76	
WILSON PETER A	7704	06177045	330.20				330.20	
KAKOURAS ATHANASIOS P	7706	06177049	491.20				491.20	
QUINN MATHEW C	7724	06177087	68.93				68.93	
BUTLER BARRY A	7834	07138176	129.48				129.48	
MORRISETTE ALEXANDER G	7882	07150645	232.82				232.82	
		TAX YEAR: 2015	<u>40,384.26</u>				<u>40,384.26</u>	
		GRAND TOTAL:	<u>40,384.26</u>				<u>40,384.26</u>	

BALANCE WITHOUT INTEREST:



Union County Sheriff's Office
Events By Nature

Date of Report

2/2/2016
9:32:57AM

For the Month of: January 2016

<u>Event Type</u>	<u>Total</u>
911 HANG UP	31
911 MISDIAL	3
ACCIDENT EMD	1
ACCIDENT PD COUNTY NO EMD	16
ACCIDENT PD MUNICIPAL	1
ALARMS LAW	48
ANIMAL BITE FOLLOW UP	2
ANIMAL BITE REPORT LAW	3
ANIMAL COMP SERVICE CALL LAW	7
ANIMAL NUISANCE CALL LAW	1
ARMED SUBJECT REPORT	1
ASSIST EMS OR FIRE	1
ATTEMPT TO LOCATE	4
BARKING DOG	1
BOLO	14
BURGLARY HOME OTHER NONBUSINESS	1
BURGLARY VEHICLE	1
BUSINESS CHECK	22
CALL BY PHONE	18
DELIVER MESSAGE	4
DISCHARGE OF FIREARM	4
DISTURBANCE OR NUISANCE	3
DOMESTIC DISTURBANCE	7
DRUG INFORMATION NOT IN PROGR	1
FIREWORKS VIOLATION REPORT	1
FOLLOW UP INVESTIGATION	5
FOOT PATROL	2
FRAUD DECEPTION FORGERY	4

<u>Event Type</u>	<u>Total</u>
INVESTIGATION	3
JURISDICTION CONFIRMATION LAW	5
LARCENY THEFT	2
LIVE STOCK ON HIGHWAY	3
LOST OR FOUND PROPERTY	1
MEET REQUEST NO REFERENCE GIVN	3
MENTAL DISORDER	1
MISSING PERSON	2
MOTORIST ASSIST	9
NOISE COMPLAINT	1
PREVENTATIVE PATROL	325
PROP DAMAGE VANDALISM MISCHIEF	6
RADAR PATROL INCLUDING TRAINIG	9
SEARCH CONDUCTED BY LAW AGENCY	1
SERVE CIVIL PAPER	1
SERVE CRIMINAL CIVIL SUBPOENA	1
SERVE EVICTION NOTICE	1
SERVE WARRANT	1
SUSPICIOUS CIRCUMSTANCES	3
SUSPICIOUS PERSON	5
SUSPICIOUS VEHICLE	14
THEFT OF VEHICLE OR PARTS	1
TRAFFIC DIRECT CONTROL	1
TRAFFIC HAZARD	1
TRAFFIC STOP	83
TRAFFIC VIOLATION COMPLAINT	25
TRESPASSING UNWANTED SUBJ	1
VEHICLE ALARM	1
VEHICLE FIRE EFD	1
WELL BEING CHECK	3

Total Calls for Month:

721

Weddington

1/2016

UCR Code	Description	Date of Report	Incident ID	
13B				
13B	ASSAULT ON FEMALE	1/30/16	201600888	
			Total:	1
220				
220	BREAKING/ENTERING-FELONY	1/25/16	201600704	
			Total:	1
23F				
23F	BEL / THEFT FROM MOTOR VEHICLE	1/6/16	201600184	
23F	BEL / THEFT FROM MOTOR VEHICLE	1/25/16	201600716	
23F	BEL / THEFT FROM MOTOR VEHICLE	1/26/16	201600734	
			Total:	3
23H				
23H	LARCENY-MISDEMEANOR	1/3/16	201600073	
			Total:	1
26A				
26A	IDENTITY THEFT	1/14/16	201600442	
26A	FRAUD-CREDIT CARD	1/23/16	201600657	
26A	IDENTITY THEFT	1/31/16	201600901	
			Total:	3
290				
290	INJURY TO REAL PROPERTY	1/2/16	201600055	
290	INJURY TO REAL PROPERTY	1/4/16	201600087	Unfounded
290	INJURY TO REAL PROPERTY	1/16/16	201600483	
290	INJURY TO PERSONAL PROPERTY	1/25/16	201600694	
290	INJURY TO PERSONAL PROPERTY	1/27/16	201600763	
290	INJURY TO REAL PROPERTY	1/31/16	201600908	
290	INJURY TO REAL PROPERTY	1/31/16	201600911	
			Total:	7
35A				
35A	POSSESS MARIJUANA UP TO 1/2 OZ	1/2/16	201600042	
			Total:	1
35B				
35B	POSSESS DRUG PARAPHERNALIA	1/2/16	201600042	
35B	POSSESS DRUG PARAPHERNALIA	1/25/16	201600699	
			Total:	2
90D				
90D	DRIVE AFTER CONSUMING < 21	1/1/16	201600006	
			Total:	1

Weddington

1/2016

UCR Code	Description	Date of Report	Incident ID
999			
999	FOUND PROPERTY	1/4/16	201600108
999	ACCIDENT NO VISIBLE INJURY	1/5/16	201600143
999	ACCIDENT NO VISIBLE INJURY	1/7/16	201600212
999	ACCIDENT NO VISIBLE INJURY	1/8/16	201600244
999	ANIMAL CALL BITE	1/11/16	201600332
999	MISSING PERSON	1/14/16	201600404
999	ACCIDENT NO VISIBLE INJURY	1/14/16	201600412
999	INVESTIGATION	1/8/16	201600422
999	ACCIDENT NO VISIBLE INJURY	1/14/16	201600438
999	ACCIDENT NO VISIBLE INJURY	1/18/16	201600547
999	INVESTIGATION	1/19/16	201600558
999	ACCIDENT POSSIBLE INJURY	1/19/16	201600568
999	ANIMAL CALL	1/19/16	201600572
999	INVESTIGATION	1/24/16	201600680
999	ANIMAL CALL BITE	1/26/16	201600730
999	ACCIDENT POSSIBLE INJURY	1/26/16	201600750
999	DOMESTIC	1/28/16	201600821
999	ACCIDENT NO VISIBLE INJURY	1/30/16	201600890
			Total: 18
9999			
9999	MENTAL HEALTH INVESTIGATION	1/29/16	201600866
			Total: 1

Monthly Crime Total **39**

Wesley Chapel Volunteer Fire Department

Incident List by Alarm Date/Time

Alarm Date Between {01/01/2016} And {01/31/2016}

Incident-Exp#	Alm Date	Alm Time	Location	Incident Type
16-1600017-000	01/01/2016	12:50:11	1404 TARRINGTON WAY /Indi	321 EMS call, excluding vehicle
16-1600018-000	01/01/2016	13:21:51	104 PRICE POINT DR /WESLE	735 Alarm system sounded due to
16-1600026-000	01/01/2016	16:43:56	517 AUCKLAND LN /WEDDINGT	311 Medical assist, assist EMS c
16-1600027-000	01/01/2016	18:14:16	4040 BLOSSOM HILL DR /Wed	700 False alarm or false call, O
16-1600039-000	01/02/2016	01:56:09	1712 CRANE RD	311 Medical assist, assist EMS c
16-1600042-000	01/02/2016	03:15:45	9217 CLERKENWELL DR	321 EMS call, excluding vehicle
16-1600045-000	01/02/2016	07:11:50	717 PILGRIM FOREST DR /We	311 Medical assist, assist EMS c
16-1600047-000	01/02/2016	09:46:30	6350 WEDDINGTON RD /Wesle	311 Medical assist, assist EMS c
16-1600052-000	01/02/2016	11:36:24	1528 S PROVIDENCE RD	733 Smoke detector activation du
16-1600060-000	01/02/2016	16:14:00	3312 SANDALWOOD DR /MARVI	113 Cooking fire, confined to co
16-1600065-000	01/02/2016	18:26:50	9005 CALITERRA DR /WESLEY	311 Medical assist, assist EMS c
16-1600071-000	01/02/2016	22:04:33	LENNY STADLER WAY & PROVI	631 Authorized controlled burnin
16-1600073-000	01/03/2016	01:25:42	2023 MAGNA LN /INDIAN TRA	311 Medical assist, assist EMS c
16-1600078-000	01/03/2016	06:03:48	1112 WOODWINDS DR /Wesley	311 Medical assist, assist EMS c
16-1600090-000	01/03/2016	15:15:37	2225 SHAGBARK LN /WEDDING	412 Gas leak (natural gas or LPG
16-1600103-000	01/03/2016	23:19:26	9109 SPRATT LN	412 Gas leak (natural gas or LPG
16-1600118-000	01/04/2016	14:50:10	1013 BERWICK CT /MARVIN,	311 Medical assist, assist EMS c
16-1600127-000	01/04/2016	23:33:06	1447 WILLOW OAKS /Wedding	321 EMS call, excluding vehicle
16-1600128-000	01/05/2016	00:42:13	TAYLOR GLENN LN & WESLEY	324 Motor Vehicle Accident with
16-1600134-000	01/05/2016	10:28:43	516 PACER LN /MARVIN, NC	611 Dispatched & cancelled en ro
16-1600141-000	01/05/2016	14:08:46	8801 LONGVIEW CLUB DR	743 Smoke detector activation, n
16-1600149-000	01/05/2016	17:36:42	8413 FAIRGREEN AV	733 Smoke detector activation du
16-1600153-000	01/05/2016	18:01:25	5602 WAXHAW HWY /Mineral	352 Extrication of victim(s) fro
16-1600158-000	01/06/2016	00:17:29	3316 PLEASANT PLAINS RD /	611 Dispatched & cancelled en ro
16-1600166-000	01/06/2016	07:46:23	708 PROVIDENCE OAK LN /WE	311 Medical assist, assist EMS c
16-1600169-000	01/06/2016	09:47:11	9620 BELLOAK LN	700 False alarm or false call, O
16-1600177-000	01/06/2016	13:22:56	1013 BERWICK CT /MARVIN,	321 EMS call, excluding vehicle
16-1600193-000	01/06/2016	21:13:48	408 OAKMONT LN	611 Dispatched & cancelled en ro
16-1600196-000	01/07/2016	00:18:48	409 DEVONPORT DR /WEDDING	611 Dispatched & cancelled en ro
16-1600200-000	01/07/2016	05:18:28	5302 GOLDMINE RD /WESLEY	611 Dispatched & cancelled en ro
16-1600205-000	01/07/2016	09:07:33	3020 THORNDALE RD /INDIAN	311 Medical assist, assist EMS c
16-1600225-000	01/07/2016	16:29:09	3005 MISTY MOSS CT	743 Smoke detector activation, n
16-1600221-000	01/07/2016	16:30:27	1009 BYRUM RD /WESLEY CHA	321 EMS call, excluding vehicle
16-1600224-000	01/07/2016	16:47:13	9121 OAK BLUFF CT /MARVIN	321 EMS call, excluding vehicle
16-1600233-000	01/07/2016	20:17:20	824 UNDERWOOD RD /Wesley	311 Medical assist, assist EMS c
16-1600235-000	01/07/2016	22:12:37	2208 WHISKERY DR	321 EMS call, excluding vehicle
16-1600239-000	01/07/2016	23:55:17	3003 SEMMES LN /INDIAN TR	311 Medical assist, assist EMS c
16-1600242-000	01/08/2016	04:49:31	1005 THORNDALE RD /INDIAN	311 Medical assist, assist EMS c
16-1600248-000	01/08/2016	10:21:15	6010 BLUEBIRD HILL LN /We	611 Dispatched & cancelled en ro
16-1600250-000	01/08/2016	10:31:04	2825 CRANE RD	311 Medical assist, assist EMS c
16-1600254-000	01/08/2016	12:05:08	1528 S PROVIDENCE RD	331 Lock-in (if lock out , use 5
16-1600256-000	01/08/2016	12:33:43	11006 MAGNA LN /Indian Tr	311 Medical assist, assist EMS c
16-1600258-000	01/08/2016	15:20:25	906 HOUSTON DR /Wesley Ch	321 EMS call, excluding vehicle
16-1600268-000	01/08/2016	19:09:03	1056 NICKALOUS DR /WESLEY	311 Medical assist, assist EMS c
16-1600286-000	01/09/2016	09:30:06	2004 PRINCESA DR /WESLEY	412 Gas leak (natural gas or LPG
16-1600290-000	01/09/2016	12:57:17	1400 CUTHBERTSON RD	311 Medical assist, assist EMS c

Wesley Chapel Volunteer Fire Department

Incident List by Alarm Date/Time

Alarm Date Between {01/01/2016} And {01/31/2016}

Incident-Exp#	Alm Date	Alm Time	Location	Incident Type
16-1600293-000	01/09/2016	15:46:41	715 LOHAVEN RD /WEDDINGT	321 EMS call, excluding vehicle
16-1600299-000	01/09/2016	18:12:29	3500 WAXHAW PKWY	571 Cover assignment, standby, m
16-1600296-000	01/09/2016	18:36:59	8020 STONEHAVEN DR /MARVI	743 Smoke detector activation, n
16-1600297-000	01/09/2016	20:10:00	6627 LOBLOLLY CIR	744 Detector activation, no fire
16-1600308-000	01/10/2016	01:09:46	9108 MONARCHOS CT /MARVIN	321 EMS call, excluding vehicle
16-1600309-000	01/10/2016	01:53:57	2400 BALTHAZAR WAY	745 Alarm system activation, no
16-1600320-000	01/10/2016	11:19:14	3002 TILLY MORRIS RD /WED	735 Alarm system sounded due to
16-1600321-000	01/10/2016	11:52:35	1440 WILLOW OAKS TR /Wedd	321 EMS call, excluding vehicle
16-1600327-000	01/10/2016	15:04:31	918 PILGRIM FOREST DR /WE	561 Unauthorized burning
16-1600330-000	01/10/2016	15:37:37	906 ROBINBROOK LN	321 EMS call, excluding vehicle
16-1600333-000	01/10/2016	17:35:27	903 BRADFORD PL /WESLEY C	561 Unauthorized burning
16-1600336-000	01/10/2016	20:04:20	311 PALMERSTON LN	311 Medical assist, assist EMS c
16-1600358-000	01/11/2016	15:23:54	532 WALDEN TR /WEDDINGTON	321 EMS call, excluding vehicle
16-1600359-000	01/11/2016	15:41:02	1112 BALTUSROL LN /MARVIN	100 Fire, Other
16-1600362-000	01/11/2016	18:20:43	NEW TOWN RD & S PROVIDENC	622 No Incident found on arrival
16-1600382-000	01/12/2016	09:36:39	2004 RIDLEY PARK CT /Indi	321 EMS call, excluding vehicle
16-1600385-000	01/12/2016	10:57:17	617 WHITE TAIL TER /MARVI	554 Assist invalid
16-1600386-000	01/12/2016	11:09:28	1405 WHISPERING OAKS LN /	321 EMS call, excluding vehicle
16-1600388-000	01/12/2016	11:28:25	512 APPOMATOX DR /MARVIN,	322 Motor vehicle accident with
16-1600401-000	01/12/2016	17:55:14	5955 WAXHAW INDIAN TRAIL	324 Motor Vehicle Accident with
16-1600408-000	01/12/2016	19:15:42	404 CONAWAY CT /Wesley Ch	710 Malicious, mischievous false
16-1600410-000	01/12/2016	20:02:46	5115 BIRCHAVEN DR /WEDDIN	321 EMS call, excluding vehicle
16-1600424-000	01/13/2016	12:55:16	1509 COX RD /Weddington,	311 Medical assist, assist EMS c
16-1600431-000	01/13/2016	15:17:44	REA RD & CREEKSTONE RD	324 Motor Vehicle Accident with
16-1600433-000	01/13/2016	15:59:27	1300 LOOK OUT CIR	440 Electrical wiring/equipment
16-1600446-000	01/14/2016	06:34:03	1351 CHESTNUT LN /INDIAN	611 Dispatched & cancelled en ro
16-1600454-000	01/14/2016	11:25:49	509 WEDDINGTON RD /WEDDIN	710 Malicious, mischievous false
16-1600456-000	01/14/2016	11:44:57	5315 WOODRIDGE DR /Wesley	321 EMS call, excluding vehicle
16-1600464-000	01/14/2016	17:55:35	WEDDINGTON RD & WESLEY CH	311 Medical assist, assist EMS c
16-1600465-000	01/14/2016	18:38:32	WAXHAW INDIAN TRAIL RD &	322 Motor vehicle accident with
16-1600479-000	01/15/2016	09:38:15	6006 CASSWELL CIR /MATTHE	746 Carbon monoxide detector act
16-1600486-000	01/15/2016	14:00:09	625 ENNIS RD /Weddington,	745 Alarm system activation, no
16-1600489-000	01/15/2016	15:40:41	314 ABELLIA DR	735 Alarm system sounded due to
16-1600500-000	01/15/2016	23:03:40	8907 CUMBERLAND CT	311 Medical assist, assist EMS c
16-1600503-000	01/16/2016	00:47:18	2101 POTTER COVE LN /WEDD	311 Medical assist, assist EMS c
16-1600504-000	01/16/2016	03:49:40	5708 ANTIOCH CHURCH RD /M	554 Assist invalid
16-1600506-000	01/16/2016	06:34:32	3711 BANYAN WAY /MARVIN,	321 EMS call, excluding vehicle
16-1600513-000	01/16/2016	07:33:56	424 WAXHAW INDIAN TRAIL R	381 Rescue or EMS standby
16-1600505-000	01/16/2016	07:36:35	7708 WESTMONT WAY	311 Medical assist, assist EMS c
16-1600510-000	01/16/2016	10:46:10	5941 WEDDINGTON RD /105/W	321 EMS call, excluding vehicle
16-1600521-000	01/16/2016	17:41:10	6390 WEDDINGTON RD /WESLE	441 Heat from short circuit (wir
16-1600534-000	01/16/2016	23:16:29	6666 NEW TOWN RD /Wesley	561 Unauthorized burning
16-1600545-000	01/17/2016	09:17:42	923 BYRUM RD /WESLEY CHAP	311 Medical assist, assist EMS c
16-1600548-000	01/17/2016	12:40:06	4028 BLOSSOM HILL DR /Wed	311 Medical assist, assist EMS c
16-1600552-000	01/17/2016	13:51:14	1264 WILLOW OAKS TR /Wedd	321 EMS call, excluding vehicle
16-1600560-000	01/17/2016	18:04:51	408 OAKMONT LN	321 EMS call, excluding vehicle

Wesley Chapel Volunteer Fire Department

Incident List by Alarm Date/Time

Alarm Date Between {01/01/2016} And {01/31/2016}

Incident-Exp#	Alm Date	Alm Time	Location	Incident Type
16-1600564-000	01/17/2016	20:00:17	4006 CLOVER HILL RD /INDI	611 Dispatched & cancelled en ro
16-1600568-000	01/17/2016	22:17:55	100 BELVEDERE LN	611 Dispatched & cancelled en ro
16-1600573-000	01/18/2016	06:47:18	601 SHERMAN PL	600 Good intent call, Other
16-1600574-000	01/18/2016	07:29:46	7416 STONEHAVEN DR /MARVI	735 Alarm system sounded due to
16-1600579-000	01/18/2016	10:19:12	824 UNDERWOOD RD /Wesley	311 Medical assist, assist EMS c
16-1600588-000	01/18/2016	15:03:28	311 PALMERSTON LN	321 EMS call, excluding vehicle
16-1600595-000	01/18/2016	21:39:35	2024 MAGNA LN /Indian Tra	311 Medical assist, assist EMS c
16-1600601-000	01/19/2016	01:58:43	2028 CLOVER HILL RD /Indi	311 Medical assist, assist EMS c
16-1600610-000	01/19/2016	09:05:33	102 E SOUTH MAIN ST	735 Alarm system sounded due to
16-1600615-000	01/19/2016	11:54:12	605 CAVENDISH LN	113 Cooking fire, confined to co
16-1600620-000	01/19/2016	14:23:23	S PROVIDENCE RD & ENNIS R	322 Motor vehicle accident with
16-1600627-000	01/19/2016	18:22:38	8316 VICTORIA LAKE DR	114 Chimney or flue fire, confin
16-1600628-000	01/19/2016	19:19:06	1400 CUTHBERTSON RD	311 Medical assist, assist EMS c
16-1600634-000	01/20/2016	01:05:21	802 SPRINGWOOD DR	311 Medical assist, assist EMS c
16-1600657-000	01/20/2016	16:22:35	BELLE GROVE DR & BONDS GR	151 Outside rubbish, trash or wa
16-1600658-000	01/20/2016	18:06:47	PROVIDENCE RD & HEMBY RD	600 Good intent call, Other
16-1600669-000	01/21/2016	07:31:31	MARVIN RD & JOE KERR RD /	322 Motor vehicle accident with
16-1600670-000	01/21/2016	07:48:58	1527 CRANE RD	311 Medical assist, assist EMS c
16-1600690-000	01/21/2016	15:41:34	1129 LAFAYETTE PARK LN /W	554 Assist invalid
16-1600693-000	01/21/2016	19:09:49	902 BRADFORD PL /Wesley C	311 Medical assist, assist EMS c
16-1600697-000	01/21/2016	19:27:18	5810 WEDDINGTON MATTHEWS	321 EMS call, excluding vehicle
16-1600700-000	01/21/2016	20:46:52	4024 PINEBROOK LN	745 Alarm system activation, no
16-1600709-000	01/22/2016	06:14:41	7306 STONEHAVEN DR /MARVI	736 CO detector activation due t
16-1600765-000	01/23/2016	03:29:33	211 MOLLIE IRENE DR /Wesl	311 Medical assist, assist EMS c
16-1600776-000	01/23/2016	09:27:33	8907 DARTINGTON LN	321 EMS call, excluding vehicle
16-1600780-000	01/23/2016	11:45:35	211 MOLLIE IRENE DR /WESL	611 Dispatched & cancelled en ro
16-1600782-000	01/23/2016	11:52:51	211 MOLLIE IRENE DR /WESL	311 Medical assist, assist EMS c
16-1600790-000	01/23/2016	13:24:41	1035 HEATHER GLEN DR /WES	412 Gas leak (natural gas or LPG
16-1600791-000	01/23/2016	13:25:33	1223 CRANE RD /Weddington	321 EMS call, excluding vehicle
16-1600813-000	01/24/2016	03:27:22	1605 AMBERGATE LN /Wesley	746 Carbon monoxide detector act
16-1600815-000	01/24/2016	04:22:05	9811 TOMPKINS LN	611 Dispatched & cancelled en ro
16-1600822-000	01/24/2016	09:32:35	668 ENNIS RD /WEDDINGTON,	352 Extrication of victim(s) fro
16-1600839-000	01/24/2016	15:42:35	6510 BUGGY WHIP LN	311 Medical assist, assist EMS c
16-1600843-000	01/24/2016	18:32:22	2706 GILEAD LN	735 Alarm system sounded due to
16-1600844-000	01/24/2016	18:49:14	6102 LOSTGATE LN /WESLEY	745 Alarm system activation, no
16-1600849-000	01/24/2016	21:07:58	6000 CLOVER HILL RD /Indi	311 Medical assist, assist EMS c
16-1600855-000	01/24/2016	23:41:46	5925 WEDDINGTON RD /Wesle	321 EMS call, excluding vehicle
16-1600857-000	01/25/2016	02:04:38	3220 OAK BROOK DR /MARVIN	611 Dispatched & cancelled en ro
16-1600863-000	01/25/2016	07:04:14	2821 BEULAH CHURCH RD /WE	324 Motor Vehicle Accident with
16-1600884-000	01/25/2016	14:22:58	9308 CLERKENWELL DR	111 Building fire
16-1600881-000	01/25/2016	14:58:47	1308 DELANEY DR /WEDDINGT	311 Medical assist, assist EMS c
16-1600882-000	01/25/2016	15:44:46	NEW TOWN RD & WAXHAW INDI	324 Motor Vehicle Accident with
16-1600887-000	01/25/2016	17:14:44	1400 CUTHBERTSON RD	321 EMS call, excluding vehicle
16-1600894-000	01/25/2016	20:57:59	7007 FOREST RIDGE RD /WED	321 EMS call, excluding vehicle
16-1600895-000	01/25/2016	21:38:48	1638 LOOK OUT CIR	321 EMS call, excluding vehicle
16-1600912-000	01/26/2016	10:59:10	3035 KINGS MANOR DR /WEDD	743 Smoke detector activation, n

Wesley Chapel Volunteer Fire Department

Incident List by Alarm Date/Time

Alarm Date Between {01/01/2016} And {01/31/2016}

Incident-Exp#	Alm Date	Alm Time	Location	Incident Type
16-1600911-000	01/26/2016	11:02:02	6033 FOGGY GLEN PL /Weddi	321 EMS call, excluding vehicle
16-1600913-000	01/26/2016	11:22:25	6033 FOGGY GLEN PL /Weddi	311 Medical assist, assist EMS c
16-1600915-000	01/26/2016	11:25:04	3035 KINGS MANOR DR /WEDD	745 Alarm system activation, no
16-1600939-000	01/27/2016	13:06:05	403 AMERSHAM LN	553 Public service
16-1600942-000	01/27/2016	15:06:12	904 OSPREY CT	735 Alarm system sounded due to
16-1600965-000	01/28/2016	10:31:15	8410 PRINCE VALIANT DR /M	311 Medical assist, assist EMS c
16-1600969-000	01/28/2016	12:10:10	110 S POTTER RD /Wesley C	321 EMS call, excluding vehicle
16-1600971-000	01/28/2016	12:22:56	4074 BLOSSOM HILL DR /Wed	321 EMS call, excluding vehicle
16-1600972-000	01/28/2016	13:52:40	8907 CUMBERLAND CT	551 Assist police or other gover
16-1600979-000	01/28/2016	16:58:27	13901 PROVIDENCE RD /Wedd	735 Alarm system sounded due to
16-1600980-000	01/28/2016	17:04:41	1049 WOODGLEN LN /Stallin	611 Dispatched & cancelled en ro
16-1600999-000	01/29/2016	10:35:22	824 UNDERWOOD RD /Wesley	321 EMS call, excluding vehicle
16-1601020-000	01/30/2016	02:29:47	701 SPRINGWOOD DR	311 Medical assist, assist EMS c
16-1601030-000	01/30/2016	11:29:02	6350 WEDDINGTON RD /Wesle	311 Medical assist, assist EMS c
16-1601031-000	01/30/2016	12:11:33	WAXHAW INDIAN TRAIL RD &	551 Assist police or other gover
16-1601043-000	01/30/2016	16:22:42	6350 WEDDINGTON RD /WESLE	321 EMS call, excluding vehicle
16-1601051-000	01/30/2016	21:03:55	519 PEMBROKE LN	743 Smoke detector activation, n
16-1601052-000	01/30/2016	21:41:04	2601 CREEK MANOR DR	745 Alarm system activation, no
16-1601057-000	01/31/2016	03:29:55	1417 CUTHBERTSON RD /Wesl	311 Medical assist, assist EMS c
16-1601063-000	01/31/2016	12:08:05	4018 LAKE PRAIRIE CT /Wed	321 EMS call, excluding vehicle
16-1601069-000	01/31/2016	14:03:44	7100 STONEHAVEN DR /MARVI	142 Brush or brush-and-grass mix
16-1601067-000	01/31/2016	15:05:00	PROVIDENCE RD & HEMBY RD	622 No Incident found on arrival
16-1601074-000	01/31/2016	17:01:39	7609 CASPIAN DR	321 EMS call, excluding vehicle
16-1601076-000	01/31/2016	17:39:28	5817 WAXHAW INDIAN TRAIL	631 Authorized controlled burnin
16-1601080-000	01/31/2016	19:05:08	815 DEERCROSS LN	324 Motor Vehicle Accident with

Total Incident Count 163